

iProx™ Inductive Proximity Sensors — Mounting Close Together

Technical Data

Ensure Reliability When
iProx Sensors Are Mounted
Close Together

October 2005
Supersedes February 2003

Description

The iProx is a powerful family of inductive proximity sensors featuring high sensing performance right out of the box. What makes the iProx unique from other inductive sensors is the ability to extensively customize the operating characteristics to suit a particular application.

Mounting Sensors Close Together

When mounting iProx sensors close together, it is necessary to take into consideration problems that can be caused by two or more sensors communicating with each other (also known as “cross-talk”). This problem can arise when two or more sensors are mounted side-by-side (as shown in **Figure 1**) or facing each other (as shown in **Figure 2**).

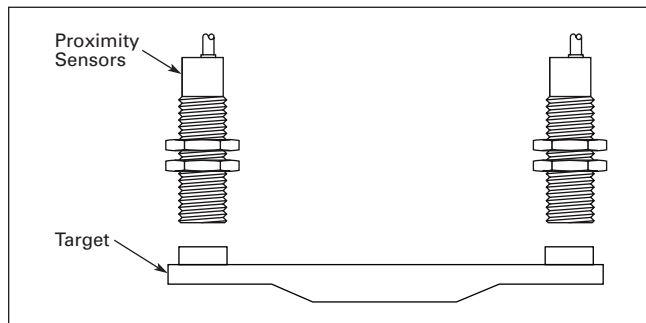

Figure 1. Prox Sensors Mounted Side-by-Side

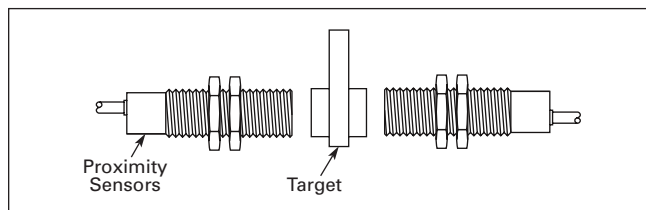

Figure 2. Prox Sensors Mounted Facing Each Other

Standard inductive proximity sensors have a similar frequency and will interfere with each other when operated close together. Until iProx, your best solution may have been to buy special sensors designed to operate on different frequencies. The disadvantage of this solution is that your choice of sensing range and body style is usually very limited.

The DC versions of iProx have three different noise immunity settings, while the AC versions have two settings. See **Figures 3, 4, 5** and **6** for optimum noise immunity settings based upon center-to-center spacing between mounted sensors. Note that in some cases, more than one noise immunity setting is available. In this case, the operator can choose the combinations of noise immunity settings most desirable for the application. The iProx breaks many of the traditional rules of inductive proximity sensors. For instance, it is possible to mount the sensors in a manner so that the sensing fields overlap, so long as the proper noise immunity settings are chosen.

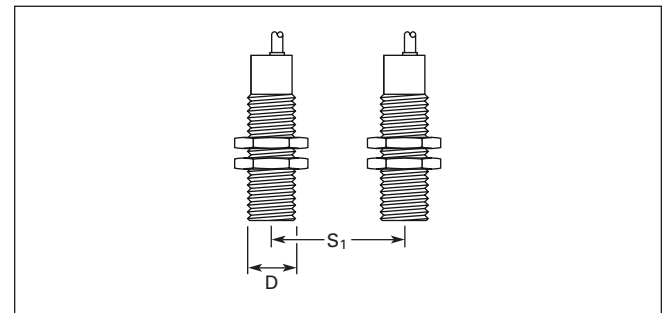

Figure 3. DC iProx Side-by-Side Configuration (S₁)

Table 1. DC iProx Side-by-Side Configuration (S₁)

Diameter (D)		Side-by-Side	High Noise Immunity	Factory Default
12 mm	Shld.	0 – 19 mm at 50 Hz	0 mm – Infinity at 10 Hz	30 mm – Infinity at 580 Hz
	Unshld.	0 – 40 mm at 50 Hz	0 mm – Infinity at 10 Hz	100 mm – Infinity at 300 Hz
18 mm	Shld.	0 – 35 mm at 50 Hz	0 mm – Infinity at 10 Hz	80 mm – Infinity at 390 Hz
	Unshld.	0 – 75 mm at 50 Hz	0 mm – Infinity at 10 Hz	130 mm – Infinity at 150 Hz
30 mm	Shld.	0 – 65 mm at 50 Hz	0 mm – Infinity at 10 Hz	110 mm – Infinity at 240 Hz
	Unshld.	0 – 75 mm at 50 Hz	0 mm – Infinity at 10 Hz	130 mm – Infinity at 90 Hz

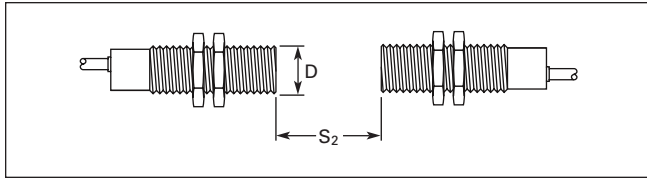

Figure 4. DC iProx Facing Configuration (S₂)

Table 2. DC iProx Facing Configuration (S₂)

Diameter (D)		Side-by-Side	High Noise Immunity	Factory Default
12 mm	Shld.	0 – 25 mm at 50 Hz	0 mm – Infinity at 10 Hz	50 mm – Infinity at 580 Hz
	Unshld.	0 – 55 mm at 50 Hz	0 mm – Infinity at 10 Hz	120 mm – Infinity at 300 Hz
18 mm	Shld.	0 – 45 mm at 50 Hz	0 mm – Infinity at 10 Hz	100 mm – Infinity at 390 Hz
	Unshld.	0 – 90 mm at 50 Hz	0 mm – Infinity at 10 Hz	160 mm – Infinity at 150 Hz
30 mm	Shld.	0 – 80 mm at 50 Hz	0 mm – Infinity at 10 Hz	130 mm – Infinity at 240 Hz
	Unshld.	0 – 90 mm at 50 Hz	0 mm – Infinity at 10 Hz	160 mm – Infinity at 90 Hz

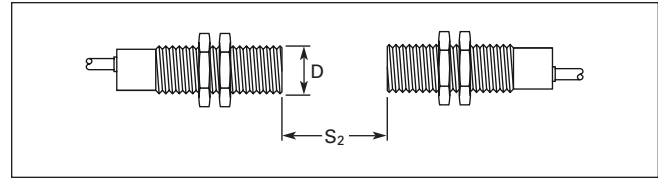

Figure 6. AC iProx Facing Configuration (S₂)

Table 4. AC iProx Facing Configuration (S₂)^②

Diameter (D)		Factory Default	High Noise Immunity
12 mm	Shld.	0 – 25 mm/50 mm – Infinity at 30 Hz	0 mm – Infinity at 10 Hz
	Unshld.	0 – 55 mm/120 mm – Infinity at 30 Hz	0 mm – Infinity at 10 Hz
18 mm	Shld.	0 – 45 mm/100 mm – Infinity at 30 Hz	0 mm – Infinity at 10 Hz
	Unshld.	0 – 90 mm/160 mm – Infinity at 30 Hz	0 mm – Infinity at 10 Hz
30 mm	Shld.	0 – 80 mm/130 mm – Infinity at 30 Hz	0 mm – Infinity at 10 Hz
	Unshld.	0 – 90 mm/160 mm – Infinity at 30 Hz	0 mm – Infinity at 10 Hz

^② These specifications may not meet final product specifications.

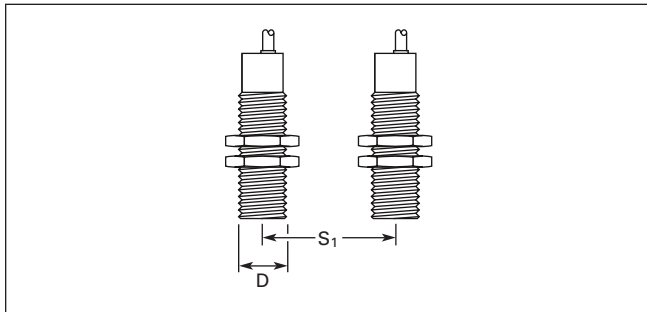

Figure 5. AC iProx Side-by-Side Configuration (S₁)

Table 3. AC iProx Side-by-Side Configuration (S₁)^①

Diameter (D)		Factory Default	High Noise Immunity
12 mm	Shld.	0 – 19 mm/30 mm – Infinity at 30 Hz	0 mm – Infinity at 10 Hz
	Unshld.	0 – 40 mm/50 mm – Infinity at 30 Hz	0 mm – Infinity at 10 Hz
18 mm	Shld.	0 – 35 mm/80 mm – Infinity at 30 Hz	0 mm – Infinity at 10 Hz
	Unshld.	0 – 75 mm/130 mm – Infinity at 30 Hz	0 mm – Infinity at 10 Hz
30 mm	Shld.	0 – 65 mm/110 mm – Infinity at 30 Hz	0 mm – Infinity at 10 Hz
	Unshld.	0 – 75 mm/130 mm – Infinity at 30 Hz	0 mm – Infinity at 10 Hz

^① These specifications may not meet final product specifications.

Note that there is a correlation between noise immunity and operating frequency. When setting the sensor for Side-by-Side sensing or High Noise Immunity, the operating frequency of the sensor will be reduced. Refer to the *iProx Programming Software User Guide* (P50228) for details.

Setting iProx for Side-by-Side or Facing Sensing

To set up iProx sensors for side-by-side or face-to-face operation, just follow the simple procedure below. This process requires that the iProx Programming Software be installed on your computer. Consult the *iProx Programming Software User Guide* (P50228) for detailed installation and operating instructions.

1. Connect the programming device to your computer. If using a Remote Programmer (E59RP1), connect it to your computer's serial port. If using the Tray Programmer (E59TP1), you have the option of connecting through serial or USB ports.
2. Launch the iProx Programming Software from the Start menu.
3. If using the Remote Programmer, affix the magnetic puck to the face of the iProx sensor. If using the Tray Programmer, securely mount the iProx sensor(s) in the programming receptacles. To ensure proper mounting, it may be necessary to remove the mounting nuts from the sensor.

4. Ensure the sensor(s) you intend to program are powered on.
5. The iProx Programming Software should automatically detect the sensor(s). See the "Connection Status" information displayed at the bottom of the "Getting Started" window to confirm the software has detected the sensor(s). If the software does not detect the connected sensor, you may need to select a wider COM port range in the software settings. For more troubleshooting information, consult the *iProx Programming Software User Guide* (P50228) by clicking on the "Help" window and selecting "Contents/FAQs."
6. From the Getting Started window, click "Configure iProx" to modify the parameters of your iProx sensor.
7. Under "Step 1: Select Sensor to Modify," click the drop-down menu and select the sensor you want to modify. It may take a few seconds to communicate with the sensor. Once this is complete, the rest of the screen should become enabled, allowing you to modify the parameters of the selected sensor.
8. Under the "Response Time/Noise Immunity" section at the top-right of the screen, drag the slider until you see the Side-by-Side value enabled.
9. Click the "Program" button at the bottom of the screen. Repeat this process for each sensor.

Side-by-Side vs. Array Sensing

Although this procedure allows sensors to be operated close to other sensors in a side-by-side configuration (see **Figure 7**), Eaton does not recommend that iProx sensors be used in an array (**Figure 8**). It is possible that cross communication can occur between sensors in an array. If the requirements of your application call for this arrangement, please contact Eaton's Sensor Application Engineering Department at 1-800-426-9184. They will work with you to find a solution.

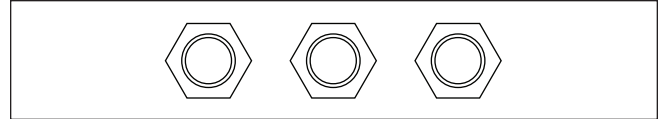

Figure 7. Sensors Oriented Side-by-Side

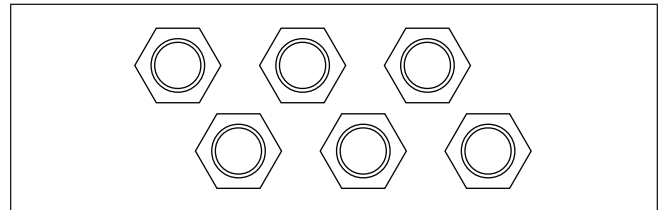

Figure 8. Sensor Oriented in an Array

Eaton Electrical Inc.
1000 Cherrington Parkway
Moon Township, PA 15108-4312
USA
tel: 1-800-525-2000
www.EatonElectrical.com



Cutler-Hammer

© 2005 Eaton Corporation
All Rights Reserved
Printed in USA
Publication No. TD05301002E/CPG
October 2005