



ALL RIGHTS RESERVED. NO PORTION OF THIS PUBLICATION, WHETHER IN WHOLE OR IN PART CAN BE REPRODUCED WITHOUT THE EXPRESS WRITTEN CONSENT OF SPC TECHNOLOGY.

SPC-F005.DWG

REVISIONS

DOC. NO. SPC-F005 \* Effective: 7/8/02 \* DCP No: 1398

DCP #	REV	DESCRIPTION	DRAWN	DATE	CHECKD	DATE	APPRVD	DATE
622	D	Was on tabular dwg TWT-*	JWM	11/5/98	JC	11/19/98	DJC	
1865	E	RoHS ADDED	DCM	10/18/05	JWM	10/19/05	JWM	10/19/05



NOTES:

1. MATERIAL: NYLON 6/6
2. COLOR: Natural
3. CONTINUOUS OPERATING TEMPERATURE:  
-40°F(-40°C) TO 167°F(75°C)
4. FLAMMABILITY: UL94V-2
5. ALL BURRS AND EXCESS FLASH MUST BE REMOVED.

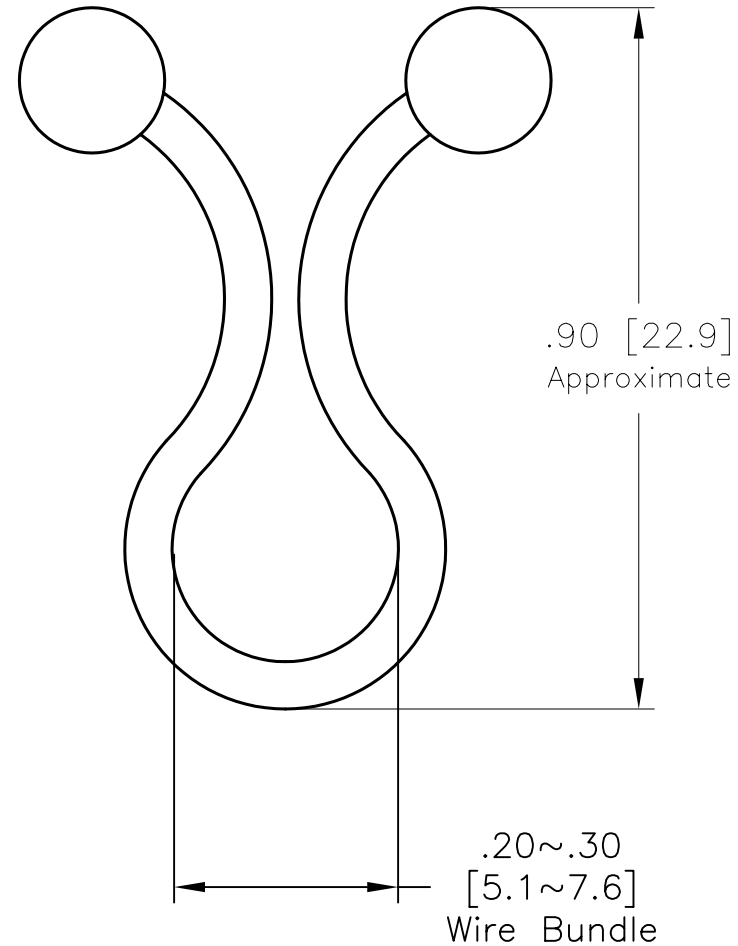

DISCLAIMER:  
ALL STATEMENTS AND TECHNICAL INFORMATION CONTAINED HEREIN ARE BASED UPON INFORMATION AND/OR TESTS WE BELIEVE TO BE ACCURATE AND RELIABLE. SINCE CONDITIONS OF USE ARE BEYOND OUR CONTROL, THE USER SHALL DETERMINE THE SUITABILITY OF THE PRODUCT FOR THE INTENDED USE AND ASSUME ALL RISK AND LIABILITY WHATSOEVER IN CONNECTION THEREWITH.

TOLERANCES:  
Tolerances Unless  
Otherwise Specified:  
.XX = ±.010  
.XXX = ±.005  
Frac. = ±1/64  
Ang = ±1°

DRAWN BY:	DATE:
J.C.	9/3/91
CHECKED BY:	DATE:
J.C.	9/3/91
APPROVED BY:	DATE:
J.C.	9/3/91

DRAWING TITLE: <b>Twist Lock</b>			
SIZE <b>A</b>	DWG. NO. <b>TWT-3</b>	ELECTRONIC FILE <b>78N594.dwg</b>	REV <b>E</b>
SCALE: NTS	U.O.M.: INCHES [mm]	SHEET: 1 OF 1	