



ALL RIGHTS RESERVED. NO PORTION OF THIS PUBLICATION, WHETHER IN WHOLE OR IN PART CAN BE REPRODUCED WITHOUT THE EXPRESS WRITTEN CONSENT OF SPC TECHNOLOGY.

SPC-F005.DWG

REVISIONS

DDC. NO. SPC-F005 \* Effective: 7/8/02 \* DCP No: 1398

| DCP # | REV | DESCRIPTION | DRAWN | DATE     | CHECKD | DATE     | APPRVD | DATE     |
|-------|-----|-------------|-------|----------|--------|----------|--------|----------|
| 2070  | A   | Released    | JN    | 09-03-09 | JWM    | 09-03-09 | JWM    | 09-03-09 |

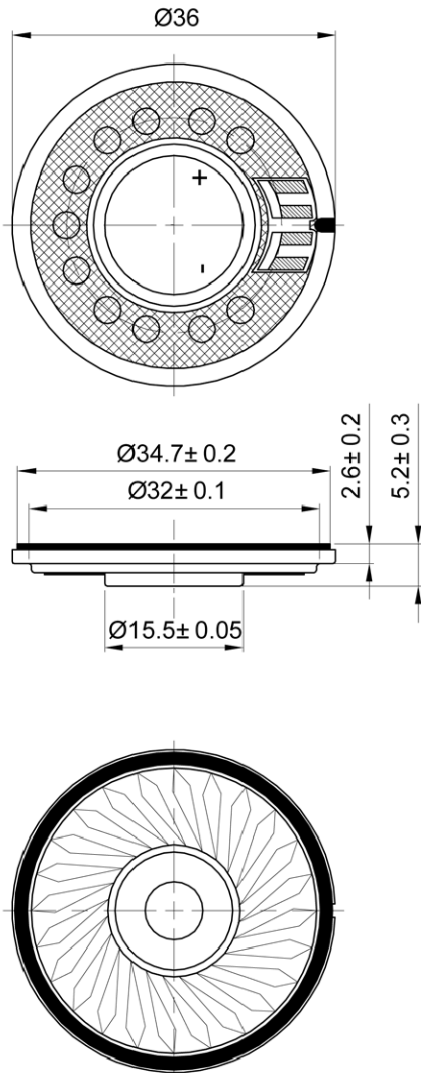

| No. | Item               | Specification   | Test Condition                                       |
|-----|--------------------|---|--|
| 1   | Impedance          | $8 \Omega \pm 15\%$   | 1Vrms at 1KHz  |
| 2   | Resonant Fr. (f o) | $400\text{Hz} \pm 20\%$   |  |
| 3   | Frequency Range    | F0-5.0KHz   |  |
| 4   | Rated Power        | 1W  |  |
| 5   | Max Power          | 1.5W  |  |
| 6   | S.P.L.             | $86 \pm 3\text{dB}$   | 1W/0.5M at AVG 0.5,0.6,0.8,1.0KHz                    |
| 7   | Distortion         | <5% Max.  | at 1kHz/0.5W   |
| 8   | Sweep Test         | must be normal  | at sine wave 2.83V                                   |
| 9   | Load Test          | after test meet item 8  | rated noise power, 24 Hrs.                           |
| 10  | Heat Test          | after test meet item 8  | $85 \pm 2^\circ\text{C}$ 16Hrs.                      |
| 11  | Cold Test          | after test meet item 8  | $-20 \pm 2^\circ\text{C}$ 16Hrs.                     |
| 12  | Humidity Test      | after test meet item 8  | $40 \pm 2^\circ\text{C}, 90/95\% \text{R.H.}$ 16Hrs. |
| 13  | Weight             |   |  |
| 14  | Polarity Test      | When supplied plus D.C. voltage to (+) terminal, the cone must move to forward. |  |

DISCLAIMER:  
ALL STATEMENTS AND TECHNICAL INFORMATION CONTAINED HEREIN ARE BASED UPON INFORMATION AND/OR TESTS WE BELIEVE TO BE ACCURATE AND RELIABLE. SINCE CONDITIONS OF USE ARE BEYOND OUR CONTROL, THE USER SHALL DETERMINE THE SUITABILITY OF THE PRODUCT FOR THE INTENDED USE AND ASSUME ALL RISK AND LIABILITY WHATSOEVER IN CONNECTION THEREWITH.

TOLERANCES:  
**UNLESS OTHERWISE SPECIFIED, DIMENSIONS ARE FOR REFERENCE PURPOSES ONLY.**

|              |          |
|--------------|----------|
| DRAWN BY:    | DATE:    |
| Jason Nash   | 09-03-09 |
| CHECKED BY:  | DATE:    |
| Jason Nash   | 09-03-09 |
| APPROVED BY: | DATE:    |
| Jason Nash   | 09-03-09 |

|                               |                  |                 |             |
|-------------------------------|------------------|-----------------|-------------|
| DRAWING TITLE:                |                  |                 |             |
| <b>Speaker &amp; Reciever</b> |                  |                 |             |
| SIZE                          | DWG. NO.         | ELECTRONIC FILE | REV         |
| A                             | MCKP3648SP1-4758 | 25R0937.dwg     | A           |
| SCALE:                        | NTS              | U.O.M:          | INCHES [mm] |
|                               |                  | SHEET:          | 1 OF 1      |