

LINEARlight

Low Power Consumption White or Colored LED Modules



The SYLVANIA LINEARlight LED modules open creative design options. These are ideal wherever temperature or space limitations prevent the use of conventional means of illumination and are available in red, orange, yellow, green, blue, and a variety of white colors.

The LINEARlight module is optimally paired with OSRAM OPTOTRONIC® 10.5 Vdc power supplies. They are easily configured with a series of power feed and board-to-board connectors.

Key Features & Benefits

- Low power consumption and variety of colors
- Size of entire module (L x W x H) 1.47ft x 0.4in. x 0.12in. (32 LEDES)
- Long life: Up to 100,000 for colored modules when Tc point is maintained at 40°C. White modules service life up to 50,000 hours.
- Optimal operation with OPTOTRONIC 10.5Vdc power supplies
- 120° beam angle
- Minimal heat generation
- Optics and connector accessories are available

Product Offering

Ordering Description	Wattage (W)	Color
LINEAR/LM01A-W3F-727 1.47FT	4.2	2700K
LINEAR/LM01A/W2-847 1.47FT*	4.2	4700K
LINEAR/LM01A-W3F-854 1.47FT	4.2	5400K
LINEAR/LM01A/W2-854 1.47FT*	4.2	5400K
LINEAR/LM01A/W2-865 1.47FT*	4.2	6500K
LINEAR/633/OS/LM01A/S1	4.2	Super Red
LINEAR/615/OS/LM01A/A1	4.2	Amber Red
LINEAR/610/OS/LM01A/O1	4.2	Orange
LINEAR/587/OS/LM01A/Y2	4.2	Yellow
LINEAR/525/OS/LM01A/T2	4.2	True Green
LINEAR/470/OS/LM01A/B1	4.2	Blue

*Limited Availability

Application Information

Applications

- Egress marking
- Border lighting
- Walkways
- Path lighting
- Edge lighting

Specification Data

Catalog #	Type
Project	
Comments	
Prepared by	Date

Ordering Information

Item Number	Ordering Abbreviation	Module Length (ft)	No. of LEDs	Power (W)	Voltage (Vdc)	Current per module (A)	Color**	Initial Lumens per module (lm)*	Lumens/ft	Watts/ft
70288	LINEAR/LM01A-W3F-727 1.47FT	1.47	32	4.2	10.5	0.4	2700K	68	46.3	2.8
70111	LINEAR/LM01A/W2-847 1.47FT***	1.47	32	4.2	10.5	0.4	4700K	57	38.8	2.8
70289	LINEAR/LM01A-W3F-854 1.47FT	1.47	32	4.2	10.5	0.4	5400K	57	38.8	2.8
70112	LINEAR/LM01A/W2-854 1.47FT***	1.47	32	4.2	10.5	0.4	5400K	57	38.8	2.8
70113	LINEAR/LM01A/W2-865 1.47FT***	1.47	32	4.2	10.5	0.4	6500K	57	38.8	2.8
70044	LINEAR/633/OS/LM01A/S1	1.47	32	4.2	10.5	0.4	Super Red-633nm	54	36.7	2.8
70007	LINEAR/615/OS/LM01A/A1	1.47	32	4.2	10.5	0.4	Amber Red-617nm	86	58.5	2.8
70083	LINEAR/610/OS/LM01A/O1	1.47	32	4.2	10.5	0.4	Orange-606nm	98	66.7	2.8
70006	LINEAR/587/OS/LM01A/Y2	1.47	32	4.2	10.5	0.4	Yellow-587nm	69	47.0	2.8
70008	LINEAR/525/OS/LM01A/T2	1.47	32	4.2	10.5	0.4	True Green-525nm	57	38.8	2.8
70009	LINEAR/470/OS/LM01A/B1	1.47	32	4.2	10.5	0.4	Blue-469nm	10	6.8	2.8

* All data is related to entire module measured at Tc point of 25°C. Data reflects statistical mean values. Actual data may differ depending on variances in the manufacturing process. End users need to put into account the lumen depreciation as the temperature rises with various thermal management solutions installed.

**CRI >70 for all 3300K. All other white color temperatures have a CRI >80.

*** Limited availability, please contact your SYLVANIA representative for more details.

Ordering Guide

LINEAR	/	633	/	S1	-	27
LINEARlight Module		Wavelength 633nm		Color Code S1=Super Red A1=Amber Red O1=Orange Y2=Yellow T2=True Green B1=Blue		Color Temperature 27 = 2700K 47 = 4700K 54 = 5400K 65 = 6500K

Power Supply Information

LED Item Number	Color	OPTOTRONIC® 6W (51502)		OPTOTRONIC 25W (51505, 51506)		OPTOTRONIC 50W (51508, 51509)	
		No. of Modules	Max. Length (ft)	No. of Modules*	Max. Length (ft)	No. of Modules*	Max. Length (ft)
70288	White (W3F)	1	1.47	5	7.4	11	16.2
70111	White (W2)	1	1.47	5	7.4	11	16.2
70289	White (W3F)	1	1.47	5	7.4	11	16.2
70112	White (W2)	1	1.47	5	7.4	11	16.2
70113	White (W2)	1	1.47	5	7.4	11	16.2
70044	Super Red	1	1.47	5	7.4	11	16.2
70007	Amber Red	1	1.47	5	7.4	11	16.2
70083	Orange	1	1.47	5	7.4	11	16.2
70006	Yellow	1	1.47	5	7.4	11	16.2
70008	True Green	1	1.47	5	7.4	11	16.2
70009	Blue	1	1.47	5	7.4	11	16.2

*Note: A maximum of three (3) LINEARlight modules may be connected in any single branch circuit. Multiple branch circuits are supported. Consult the wiring diagram for more details.

Accessories



Item Number	Ordering Description	Length (in.)	Viewing Angle
70072	LINEARLT Optics OS-OP4x1-20 +OS-LM01A	2.2	20/20°
70015	LINEARCONN/LM2-PIN/Feeder	0.54	N/A
70116	LINEARBBCONN/LMCONN	0.44	N/A
70133	LINEARLIGHTCONN/LMCONN-50	0.54	N/A
71236	LINEARlight Track 1.6P	18	N/A
71237	LINEARlight Track 4.6P	56	N/A
71238	LINEARlight Track 1.6D	18	N/A
71239	LINEARlight Track 4.6D	56	N/A

Minimum and Maximum Ratings

Parameter	Symbol	Values
Operating Temperature at Tc Point	T_{op}	-30 to +75°C (-22 to +167°F)
Storage Temperature	T_{stg}	-30 to +85°C (-22 to +185°F)
Voltage Range	V_{max}	11.5 V_{dc}
Maximum Reverse Voltage	V_R	11.5 V_{dc}

Notes:

- Exceeding maximum ratings may damage the LED module and cause potential safety hazards.
- Elevated operating temperatures can be expected to negatively impact the service life in terms of lumen output.

Assembly Diagram

	Length in (mm)	Width in (mm)
Entire PCB	17.6 (448)	0.4 (10)
Smallest Unit	2.2 (56)	0.4 (10)
LED Spacing	0.55 (14)	

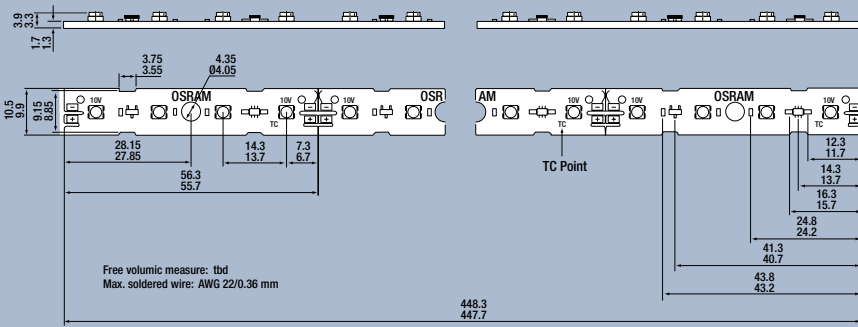

Wiring Diagram

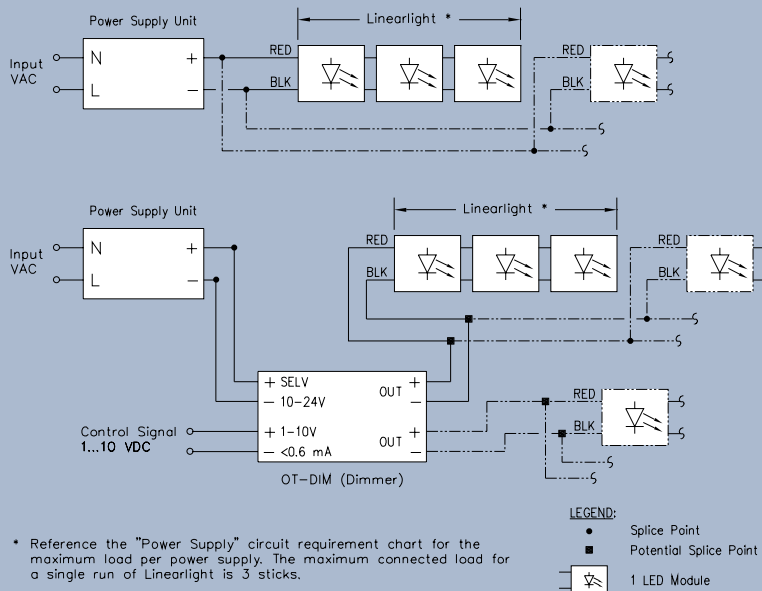

Safety Information

1. The LED module itself and all its components must not be mechanically stressed.
2. Assembly must not damage or destroy conducting paths on the circuit board.

The LED module incorporates no protection against short circuits, overload or overheating. Therefore it is necessary to operate the modules with an electronically stabilized power supply offering protection against the above mentioned safety risks. OSRAM OPTOTRONIC power supplies are specifically designed with protection features for safe operation. When using power supplies other than OPTOTRONIC the following basic safety features should be verified in addition to any other application-specific concerns and local safety codes:

- Short circuit protection
- Overload protection
- Overheat protection
- Correct output voltage, including consideration for ripple and spikes

3. Installation of LED modules (with power supplies) needs to be made with regard to all applicable electrical and safety standards. Only qualified personnel should be allowed to perform installations.
4. Correct electrical polarity needs to be observed. Wrong polarity will result in no light emission and may destroy the module.
5. A maximum of 3 Modules can be installed consecutively from any power feed. Operation with more than 3 LINEARlight modules will reduce photometric performance and exceed the current carrying capacity of the module.
6. The LINEARlight can typically survive transient current levels of up to 2 Amps. As a general design precaution, if the maximum output current of the power supply is more than 2 Amps, fast-blow fuses should be incorporated into the wiring plan.
7. Pay attention to standard ESD precautions when installing the module.
8. The module, as manufactured, has no conformal coating and therefore offers no inherent protection against corrosion. The ability to customize the length of the module by cutting at specifically marked points is a key feature of the product and hence the reason for no factory installed conformal coating. For these reasons, it is recommended that the user complete all module modifications first (cutting, wiring) and then apply a conformal coating in the final stages of installation.
9. Damage by corrosion will not be honored as a materials defect claim. It is the user's responsibility to provide suitable protection against corrosive agents such as moisture and condensation and other harmful elements.
10. For application involving exposure to humidity and dust the module must be protected by a fixture or housing with a suitable protective covering. The module can be protected against condensation water by treatment with an appropriate circuit board grade conformal coating. The conformal coating should have the following features:
 - Optical transparency
 - UV-resistance
 - thermal expansion matching the thermal expansion of the module $15-30 \times 10^{-6} \text{ cm/cm/K}$
 - low permeability of steam for all climatic conditions
 - resistance against corrosive environment

The lacquer APL of the company Electrolube <http://www.electrolube.com> has met the conditions for LINEARlight in our tests.

Assembly Information

1. Solder connections should only be performed on designated solder pads (marked "10V +/-"). During soldering, do not exceed the maximum soldering time of 10 seconds and the maximum soldering temperature of 260°C.
2. Each module can be separated into submodules of 4 LEDs each by carefully sawing or cutting at the marked lines.
3. For connector information contact SYLVANIA.
4. The mounting of the module is carried out by attaching it at the mounting holes. Mounting screws should be treated with synthetic washers to prevent circuit board damage and possible short circuiting.

SYLVANIA is a registered trademark of OSRAM SYLVANIA Inc.
OSRAM and OPTOTRONIC are registered trademarks of OSRAM GmbH.
Specifications subject to change without notice.

OSRAM SYLVANIA
National Customer
Service and Sales Center
18725 N. Union Street
Westfield, IN 46074 USA

Industrial Commercial
Phone: 1-800-255-5042
Fax: 1-800-255-5043

National Accounts
Phone: 1-800-562-4671
Fax: 1-800-562-4674

OEM/Special Markets
Phone: 1-800-762-7191
Fax: 1-800-762-7192

Display/Optic
Phone: 1-888-677-2627
Fax: 1-800-762-7192

In Canada
OSRAM SYLVANIA LTD
Headquarters
2001 Drew Road
Mississauga, ON L5S 1S4

Industrial Commercial
Phone: 1-800-263-2852
Fax: 1-800-667-6772

Special Markets
Phone: 1-800-265-2852
Fax: 1-800-667-6772

Visit our website: www.sylvania.com