

POWER MANAGEMENT PRODUCT SELECTION GUIDE



Volume 1

International
IOR Rectifier

THE POWER MANAGEMENT LEADER

THE POWER MANAGEMENT LEADER: International Rectifier is a pioneer and world leader in advanced power management technology, from digital, analog and mixed signal ICs to advanced circuit devices, power systems, and components.

Technological breakthroughs from IR are setting the pace for innovation in the electronics we all rely upon each day. Inside our factories and automobiles, at our homes and offices, and orbiting our world, IR's power management technology is enabling today's leading-edge computers, appliances, lighting, automobiles, satellites, and defense systems and creating a pathway to tomorrow's advancements.

TABLE OF CONTENTS

TYPICAL POWER APPLICATIONS

AC-DC Systems / DC-DC Systems

Desktops	p 1
Isolated DC-DC	p 1
Non-Isolated DC-DC	p 2
OR'ing	p 2

Audio / Automotive Systems

Class D Audio	p 3
Body Control	p 4
Electric Power Steering	p 3
Engine Control / Powertrain	p 3
HID	p 4

Lighting Systems

Halogen	p 5
HID	p 5
Linear Fluorescent Ballasts	p 5
LED	p 5

Motion Control, Appliances

AC Motors	p 7
Air Conditioners	p 7
Networking Communications	p 7
Refrigerators	p 6
Washing Machine	p 6

Motion Control, Integrated Design Platform

PRODUCT FAMILIES

DCBus chipsets	p 11
IC - AC-DC (PFC & Synchronous Rectification)	p 12-15
IC - Class D Audio	p 16
IC - Current Sensing ICs	p 17
IC - Digital Control ICs	p 18
IC - High Voltage ICs	p 19-23
IC - iPowir Integrated ICs and MOSFETs	p 24-25
IC - Lighting ICs	p 26-31
IC - Low Voltage Switching Regulators	p 32
IC - Multiphase Interleaved Buck Converters	p 33
IGBT - Discrete	p 34-35
Intelligent Power Modules	p 36
Intelligent Power Switches	p 37-40
MER	p 41-43
MOSFET - Automotive Trench	p 44-45
MOSFET - DirectFET	p 46-47
MOSFET - FetKY MOSFETs	p 48
MOSFET - FlipFET MOSFETs	p 49
MOSFET - Low Voltage MOSFETs	p 50
MOSFET - Mid Voltage MOSFETs	p 50
MOSFET - P-Channel	p 51

REFERENCE DESIGNS

Reference Designs - AC-DC	p 55
Reference Designs - Appliance	p 56
Reference Designs - DC-DC IC	p 57
Reference Designs - Fluorescent Ballast	p 58
Reference Designs - Motion Control	p 59

RESOURCES

Die Sales	p 63-64
myPOWER	p 65
RoHS / Lead Free	p 66
TAC Center	p 67-68

INDEX

Alphanumeric part index	p 71-73
Contact information	Inside back cover

TYPICAL APPLICATIONS



AC-DC / DC-DC Systems Typical Applications

AC-DC SYSTEMS

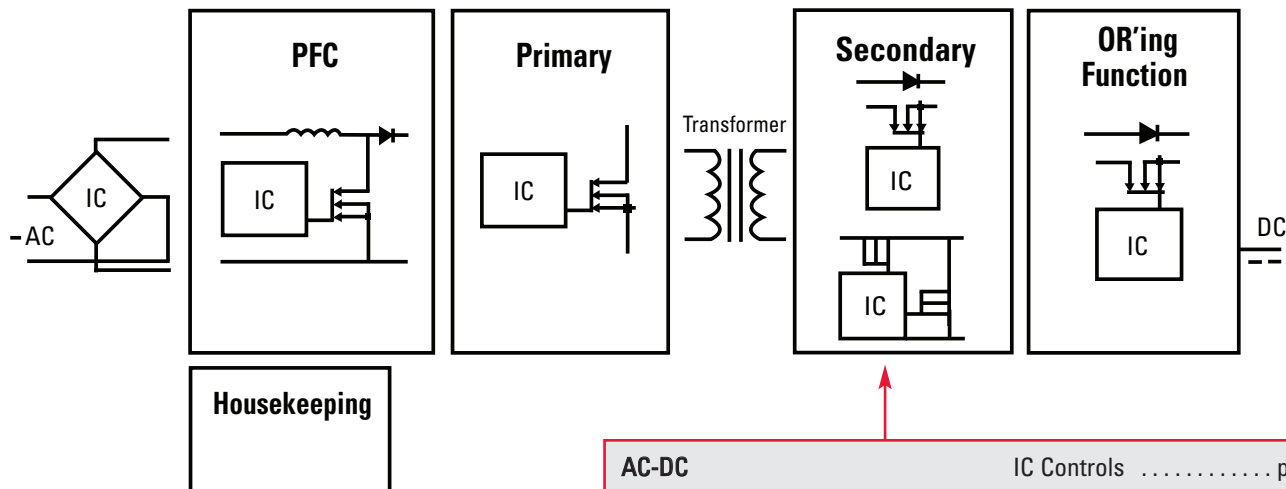

AC-DC	IC Controls p 19-23
Housekeeping –	IC Drivers p 19-23
IC Controls p 12-15	Secondary Side –
Switches p 50	IC Control p 19-23
PFC –	IC Drivers p 32
PFC ICs p 12-15	Switches p 50
IC Gate Drivers p 19-23	OR'ing Function –
Switches p 50	IC Drivers p 19-23
Primary Side –	Switches p 50
Switches p 50	

DC-DC SYSTEMS

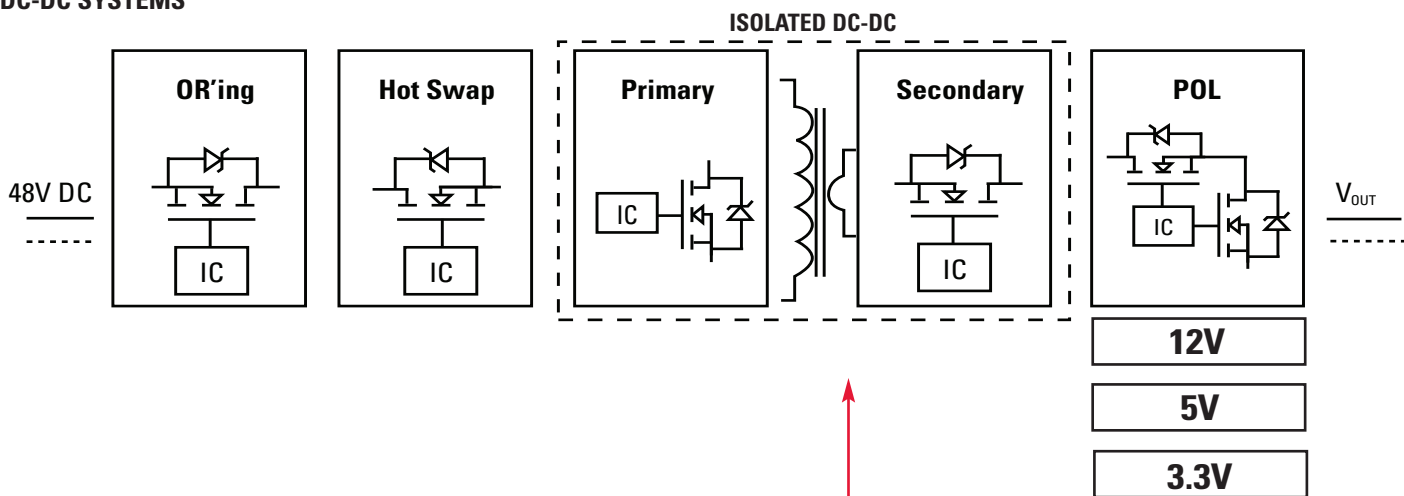

DC-DC	Secondary Side –
OR'ing FETs p 46-47	MOSFETs p 50
Hot Swap –	POL –
Hot Swap FETs p 50	Synch Buck ICs p 19-23
Primary Side –	Control FETs p 50
IC p 19-23	Synch FETs p 50
MOSFETs p 50	<i>iPOWIR™</i> devices p 24-25
	DirectFET® MOSFETS ... p 46-47

Typical Applications **DC-DC Systems**

DC-DC APPLICATIONS FOR NON-ISOLATED SWITCHING REGULATORS

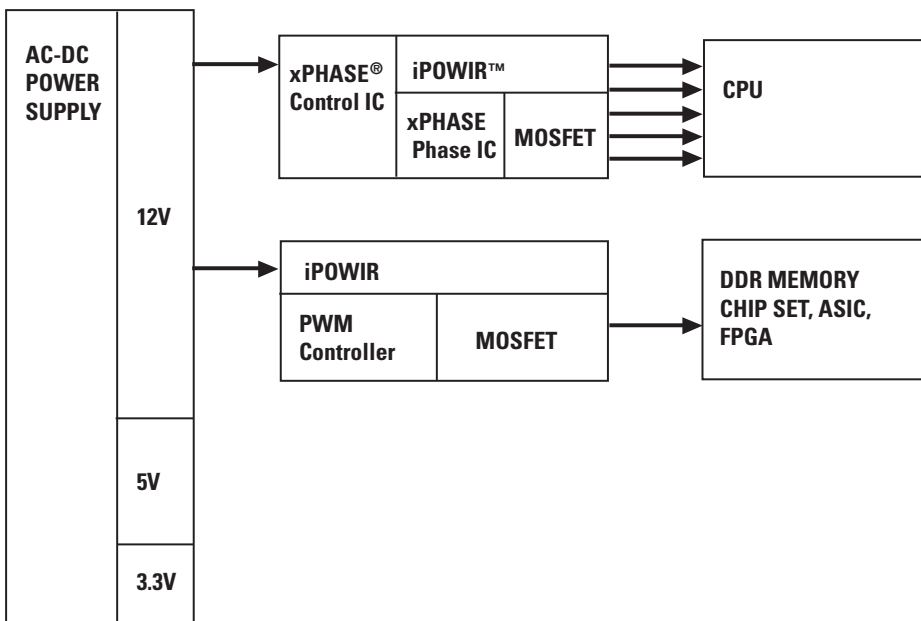

XPhase® Control IC	p 33
XPhase Phase IC	p 33
iPOWIR building blocks	p 24-25
PWM Controller ICs	p 32
Linear Regulators	p 32
MOSFETs	p 50

DC-DC NON-ISOLATED POINT-OF-LOAD (POL) IC SWITCHING REGULATORS

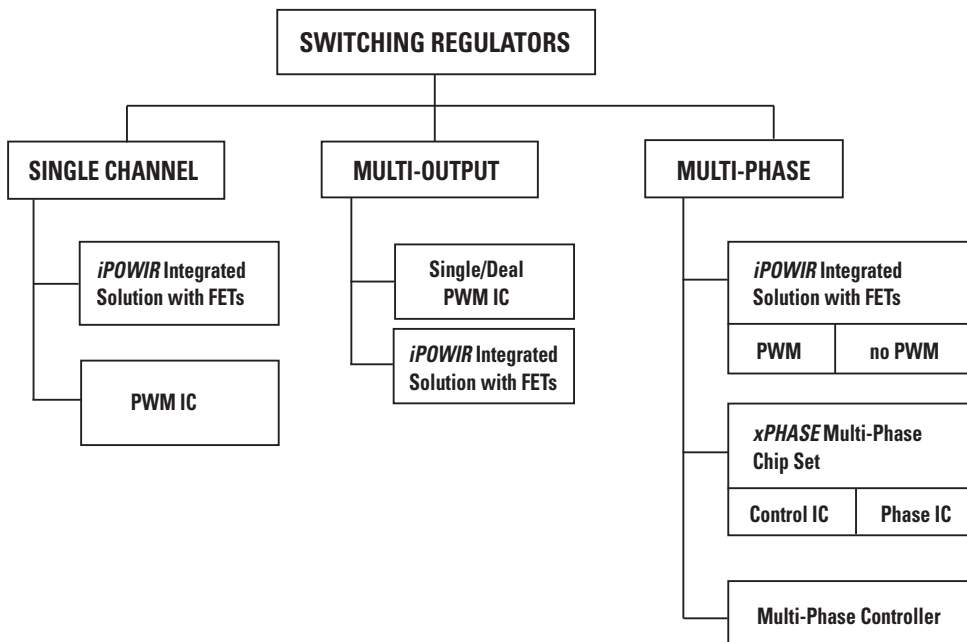

Single Channel	p 32
Multi-Output	p 32
Multi-Phase	p 32
iPOWIR building blocks	p 24-25
XPhase Chipsets	p 33
MOSFETs	p 50

Audio / Automotive Typical Applications

CLASS D AUDIO AMPLIFIER

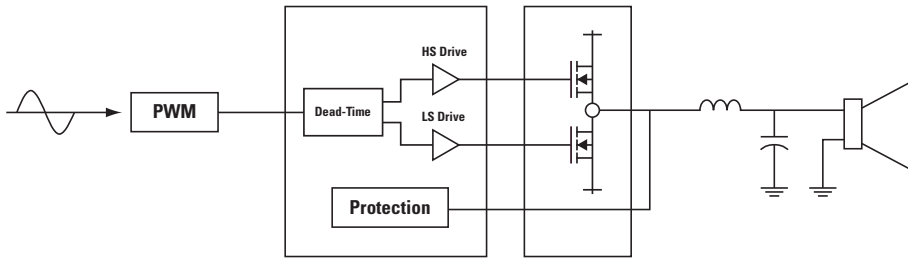

Output MOSFETs p 50
 Amplifier DirectFET®
 MOSFETs p 47
 Gate Driver ICs p 16

AUTOMOTIVE ELECTRONIC POWER STEERING

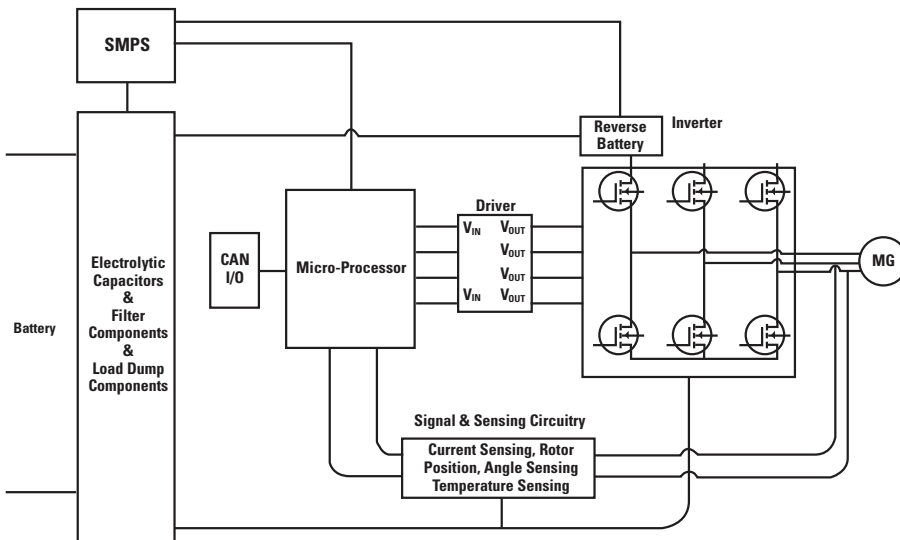

HEXFET MOSFETs p 44-45
 Gate Driver ICs p 19-23

AUTOMOTIVE ENGINE CONTROL / POWERTRAIN

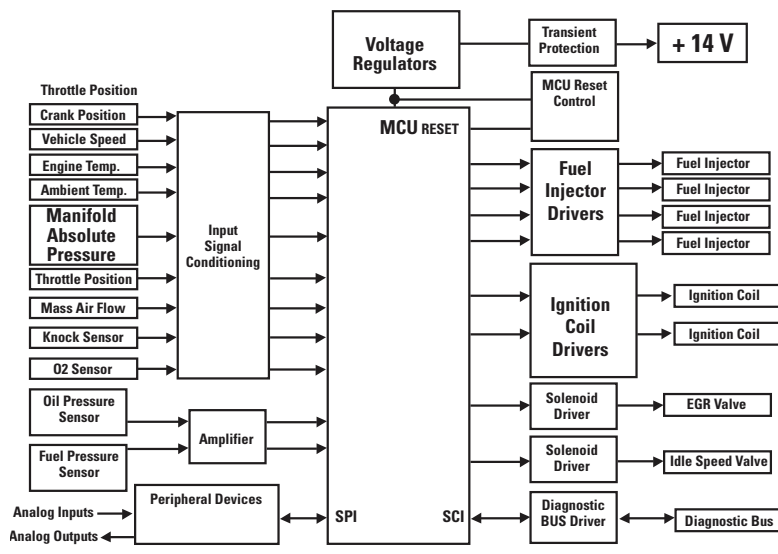

Fuel injection Drivers p 23
 Ignition Coil Drivers p 34-35

Typical Applications Automotive

AUTOMOTIVE HID

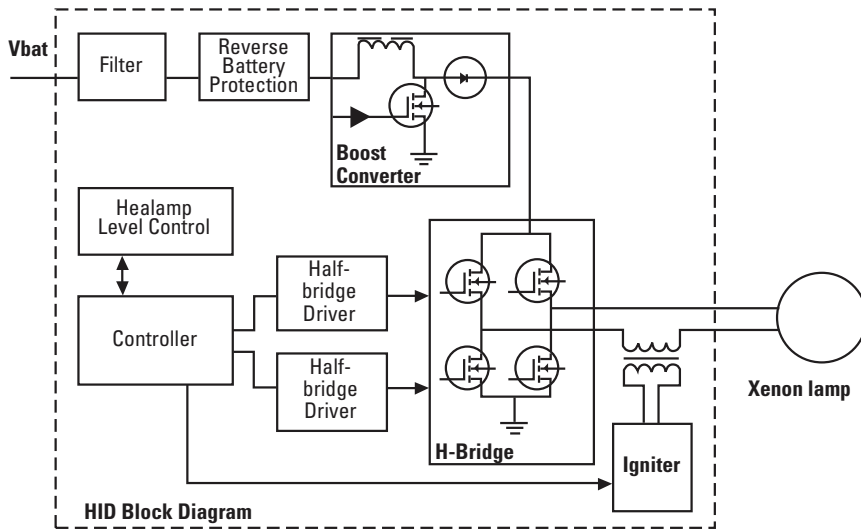

← Half-Bridge MOSFETs ... p 44-45
Half Bridge Drivers p 31

AUTOMOTIVE BODY CONTROL

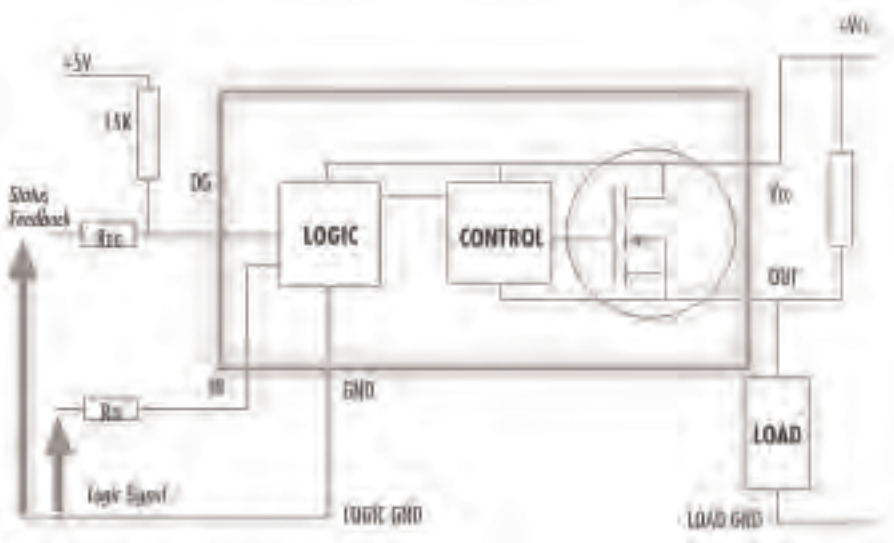

← Intelligent Power Switches p 37-40
Low-side Drivers p 30
High-side Drivers p 31

Lighting Systems Typical Applications

LINEAR FLUORESCENT BALLAST CONFIGURATION

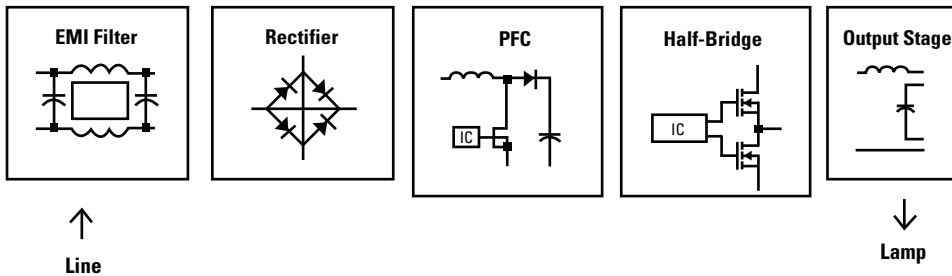

PFC and Ballast Control IC .. p 26
Ballast Control ICs p 26

HALOGEN BALLAST CONFIGURATION

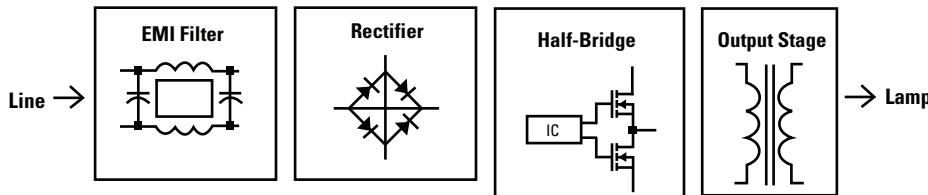

Converter Control IC p 28
Half-Bridge Driver IC p 28

HID BALLAST CONFIGURATION

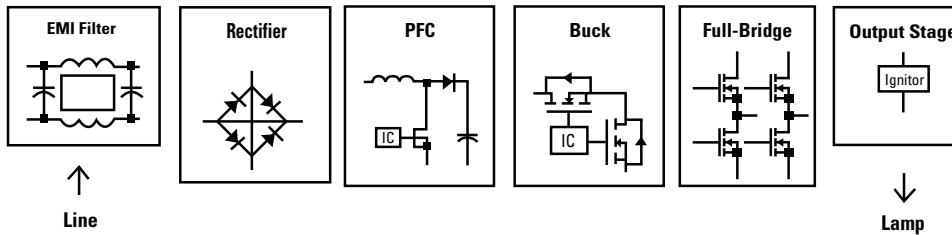

PFC ICs p 15
High-side Driver IC p 30-31
High and Low-side Driver IC . p 31
Full Bridge Driver IC p 31

LED CONFIGURATION

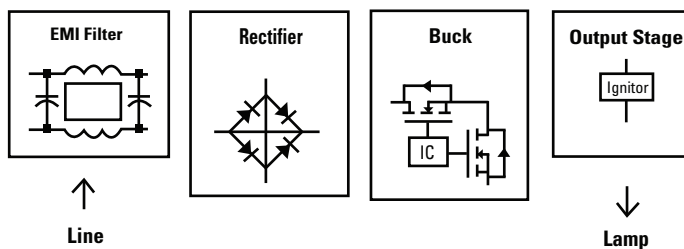

Control ICs p 27
MOSFETs p 50

Typical Applications **Motion Control**

MOTION CONTROL INTEGRATED DESIGN PLATFORM

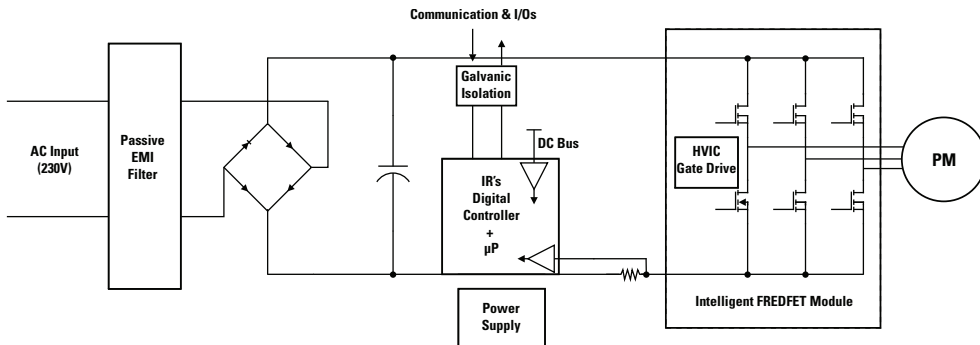

PFC ICs	p 15
Digital Control ICs	p 18
IGBT	p 34
Power MOSFETs	p 50-51
Current Sense ICs	p 17
HV Gate Driver ICs	p 19-23
Integrated Power Modules	p 36

REFRIGERATOR BLOCK DIAGRAM

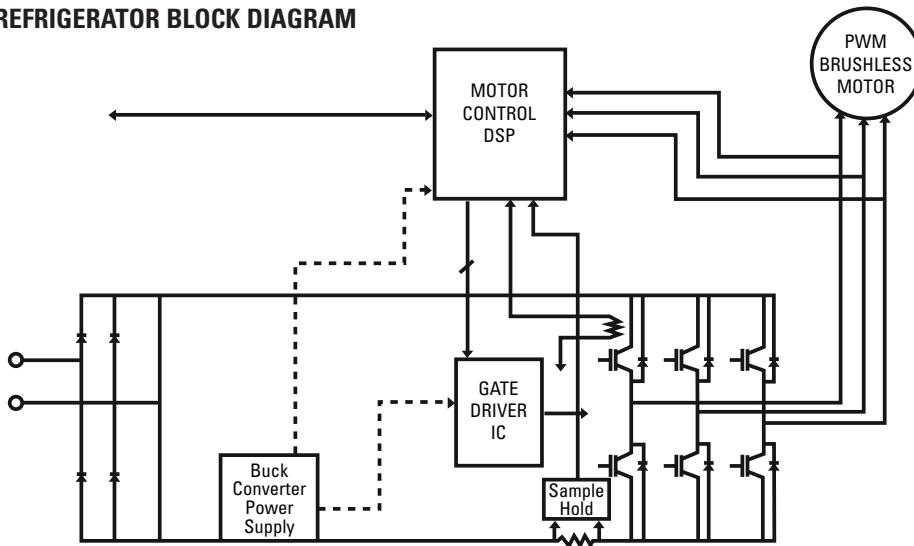

Integrated Power Modules	p 36
Mini-sip Modules	p 36
3-Phase Gate Driver IC	p 21
High and Low-side Driver IC	p 23
Half-Bridge Gate Driver IC	p 23
Current Sensing ICs	p 17
Trench IGBT Co-Pack	p 34

WASHING MACHINE BLOCK DIAGRAM

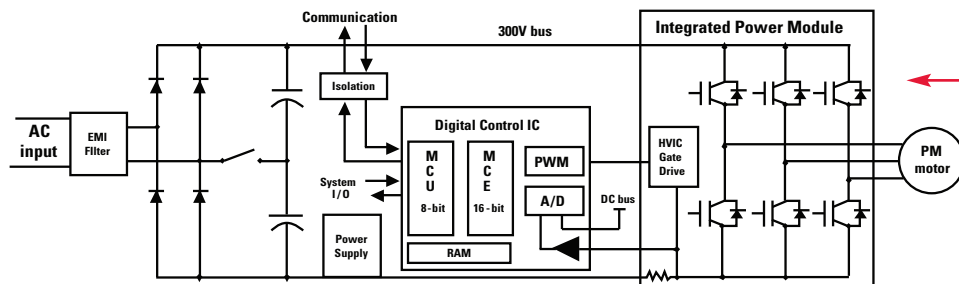

Integrated Power Modules	p 36
3-Phase Gate Driver IC	p 21
High and Low-side Driver IC	p 23
Half-Bridge Gate Driver IC	p 23
Current Sensing ICs	p 17
PFC ICs	p 15
Trench IGBT Co-Pack	p 34

Motion Control Typical Applications

AIR CONDITIONING — INTEGRATED DESIGN PLATFORM

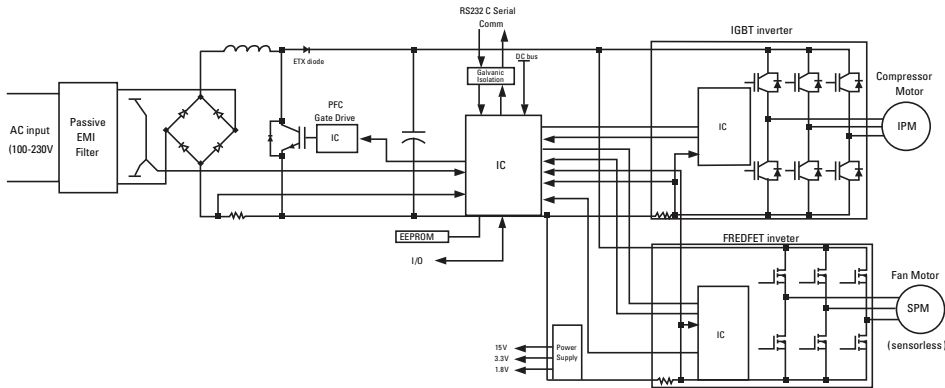

PFC ICs	p 15
Digital Control ICs	p 18
IGBT	p 34
Current Sense ICs	p 17
HV Gate Driver ICs	p 19-23
Intelligent Power Modules		p 36

AIR CONDITIONING — TRADITIONAL DISCRETE DESIGN

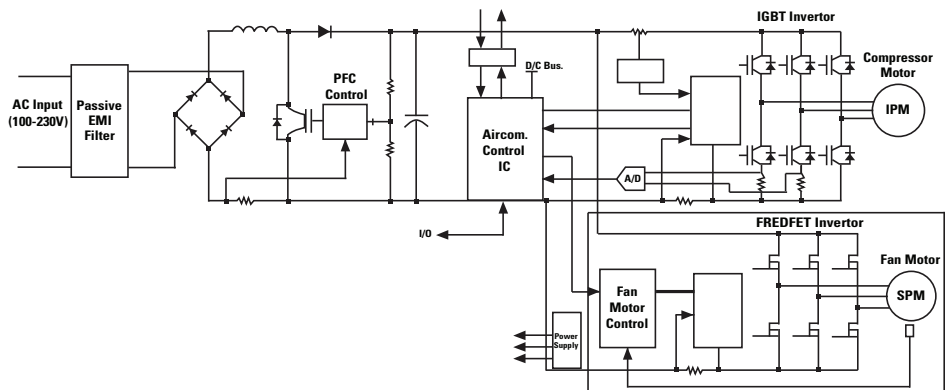

3-Phase Gate Driver IC	p 21
Current Sensing ICs	p 17
PFC ICs	p 15
Trench IGBT Co-Pack	p 34

AC MOTOR

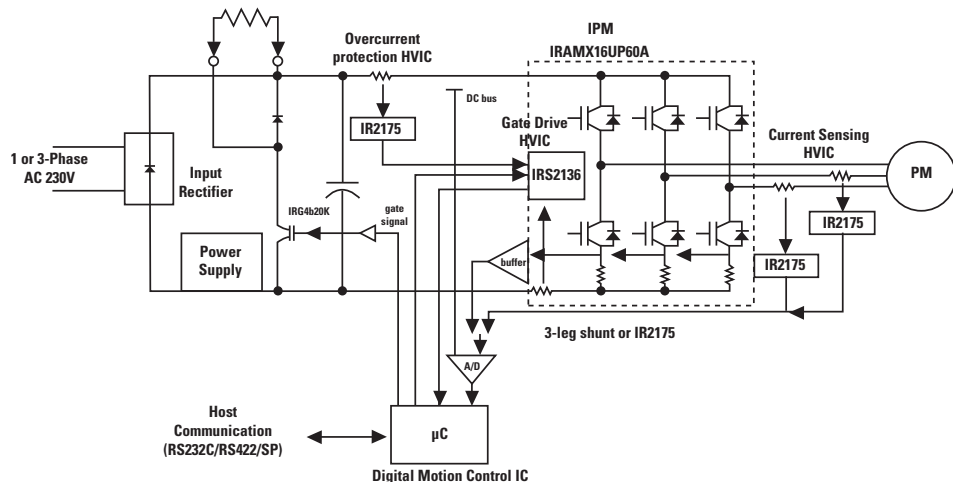

Current Sensing ICs	p 17
3-Phase Gate Driver ICs	p 21

PRODUCT FAMILIES



DC Bus Converter IC Product Families

Features at a Glance

- Optimized IC & MOSFETs for best electrical and thermal performance
- DC Bus primary side controllers
- +/- 1A gate drive current
- Optimized for IR's low charge MOSFETs
- Adjustable dead-time (50nsec to 200nsec)
- High & low pulse-width matching to within +/-25nsec
- Programmable switching frequency up to 500kHz
- Integrated soft-start
- Vcc supply under-voltage lock-out
- Current limit

IR2085S

- Self-oscillating, 50% duty cycle design with 100V offset half-bridge driver in a single 8 pin SOIC package

IR2086S

- Self-oscillating, 50% duty cycle design with 100V offset full-bridge driver in a single 16 pin SOIC package

The IR Advantage

- Optimized solution for 2-stage 48V distributed power architectures
- Dramatic space savings with increased efficiency versus standard isolated brick solutions
- Significant component count reduction, and simplification of design
- Single isolated 48V bus converter to generate unregulated low output voltage in 6V-12V range
- Bus voltage can be optimized according to power level, input voltage range, and POL switching losses:
 - Select higher bus voltage for higher power systems to reduce distribution losses
 - Select lower bus voltage for reduced switching losses in the POL

Applications

- 48V input Isolated DC-DC Converter Applications
 - 48V +/-10%
 - ETSI (36V-60V)
- Networking & Telecommunications systems
- 48V Servers & High End Computing

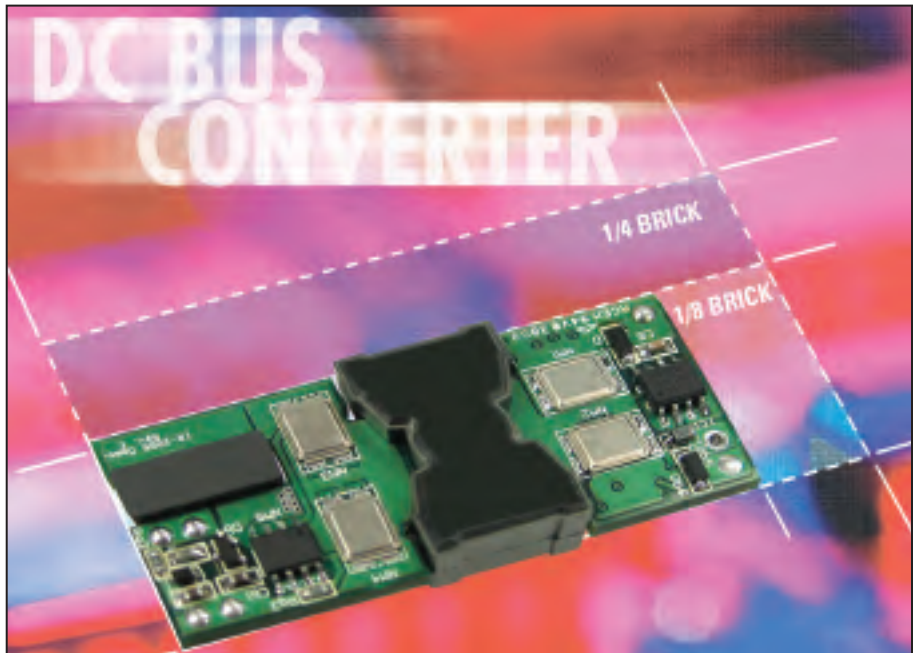

DC Bus Converter Chip Sets: Redefining On-Board Power Management

IR's DC Bus Converter chip set family is aimed at simplifying and improving on-board power management for today's networking & communications and high end computing systems. IR's DC Bus converter chip sets redefine what was previously possible in standard brick footprints, addressing power levels up to 350W without having to parallel converters. The Half-Bridge chip set offers designers up to 95.7% efficiency at 27.5A/8V/220W output, up to 126W/in² power density in 48% smaller footprint compared to standard quarter-bricks. The Full-Bridge chip set offers designers up to 97% efficiency at 35A/9.6V/330W output, up to 142W/in² power density in a 29% smaller footprint, compared to standard quarter-bricks. The DC Bus chipset allows for significant component count reduction up to 60% versus standard full-featured isolated DC-DC brick solutions.

DC Bus Converter Control ICs

Part Number	Description	Package	T _J	Drive Current	Adjustable Deadtime	Fixed Duty Cycle	Hiccup Current Limit	Soft Start	Programmable Frequency
IR2085S	Primary-side half-bridge control IC, fixed 50% duty cycle, self-oscillating	SO-8	-40 to 125°	+/- 1.0A	●	●	●	●	●
IR2086S	Primary-side half-bridge control IC, fixed 50% duty cycle, self-oscillating	SO-16	-40 to 125°	+/- 1.2A	●	●	●	●	●

DirectFET™ MOSFETs

Part #	Package	V _{DSS}	R _{DS(on)} MAX @ V _{GS} =10V	Q _G Typical	Q _{GD} Typical
IRF6644	Medium Can	100V	13mΩ	35nC	11.5nC
IRF6655	Small Can	100V	62mΩ	8.7nC	2.8nC
IRF6646	Medium Can	80V	9.5mΩ	36nC	12nC
IRF6613	Medium Can	40V	3.4mΩ	42nC	12.6nC
IRF6614	Small Can	40V	8.3mΩ	19nC	6.0nC
IRF6635	Medium Can	30V	1.8mΩ	47nC	17nC



SmartRectifier™ IR1166/67: Simple, High Efficiency Synch Rec

For designers of high power flyback and resonant 1/2 bridge converters for laptops, mini-PCs, LCD & PDP TVs and games SMPS, the SmartRectifier™ offers a simple, high efficiency solution for secondary synchronous rectification (SR) in all operational modes and application conditions.

The IR1166/67 is a secondary control IC with built-in 7A gate drive. Operating independently from the primary side, it uses a proprietary 'Voltage Level Detection' technique to minimize wasteful secondary reactive currents to maximize secondary efficiency.

The proprietary 200V HVIC technology allows direct sensing and control of IR's world-class range of Standard- or Logic-Level, 30-200V HEXFET MOSFETs.

Specifications

Part #	Package	V _{CC}	V _{FET}	Sw Freq. Max	Gate Drive +/-	V _{GATE} Clamp	Sleep Current Max	RoHS
IR1166SPbF	SO-8	20	<= 200	500	+1/-3.5	10.7	200	✓
IR1166PbF	Dip 8							
IR1167ASPbF	SO-8	20	<= 200	500	+2 / -7	10.7	200	✓
IR1167BPbF	Dip 8					14.5		
IR1167ASPbF						10.7		
IR1167BPbF						14.5		

Part #	B _{Vdss}	R _{DS(on)}	Package
IRFB3206PbF	60V	3.0mΩ	TO-220
IRFB3306PbF	60V	4.2mΩ	TO-220
IRF7855PbF	60V	9.4mΩ	SO-8
IRFB3207PbF	75V	4.1mΩ	TO-220
IRFB3307PbF	75V	5.8mΩ	TO-220
IRF7854PbF	80V	13.4mΩ	SO-8
IRFB4110PbF	100V	4.5mΩ	TO-220
IRFB4310PbF	100V	7.0mΩ	TO-220
IRF7853PbF	100V	18.0mΩ	SO-8
IRFB4321PbF	150V	15.0mΩ	TO-220
IRFB4227PbF	200V	24.0mΩ	TO-220

See www.irf.com for full MOSFET selection

The IR Advantage

- Simple, powerful solution
- Enables
 - Higher efficiency
 - Higher Power density
 - Faster time to market
- Complies with CEC 80plus and 1W standby requirements
- Proprietary Voltage Level Detection and 200V HVIC technology
- Direct connection and drive to all 30-200V MOSFETs
- Fast, powerful (7A), Accurate, high efficiency operation up to 500kHz
- Independent from primary side
- Operates in all modes
- In 120W laptop adaptor, enables
 - 1% efficiency increase
 - 10°C lower temperature
 - 75% fewer SR components
 - 20% lower SR system cost
- Enables 'no heatsink' SR designs



IR1166/67 can be used with IR's HEXFET® Power MOSFETs to provide the ultimate Smart Rectifier chip-set solutions.

AC-DC Synch Rectification ICs and MOSFETS Product Families

APPLICATION EXAMPLE:

120W Laptop adaptor (Sony, 16.5V, 6.15A) 'No heatsink' redesign

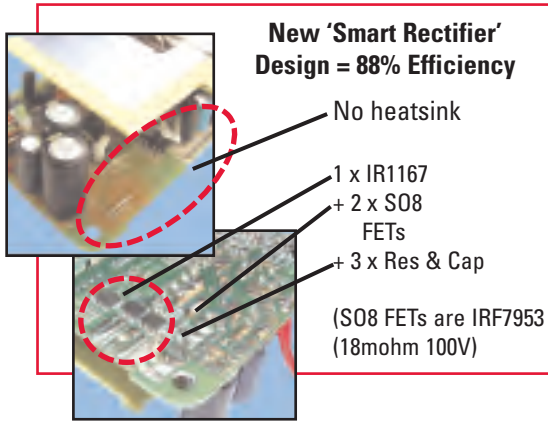

Original 'CT' Design = 87% Efficiency

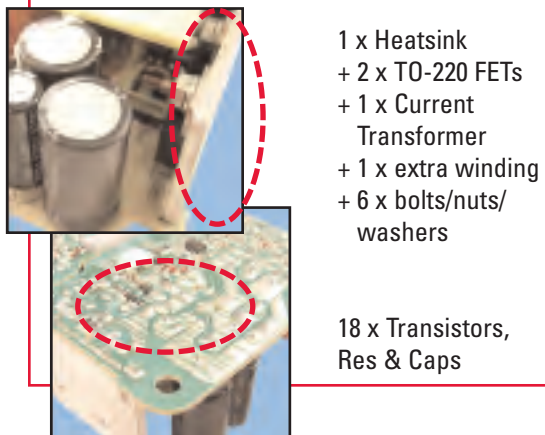

- No manual assembly
- Less space needed... can redesign to increase power density!

Old Current Transformer vs. New SmartRectifier™

120W Laptop Adaptor
 (VOUT=19.5V, IOUT=6.15A, Full Load, 110VACIN, TAMB=45°C)

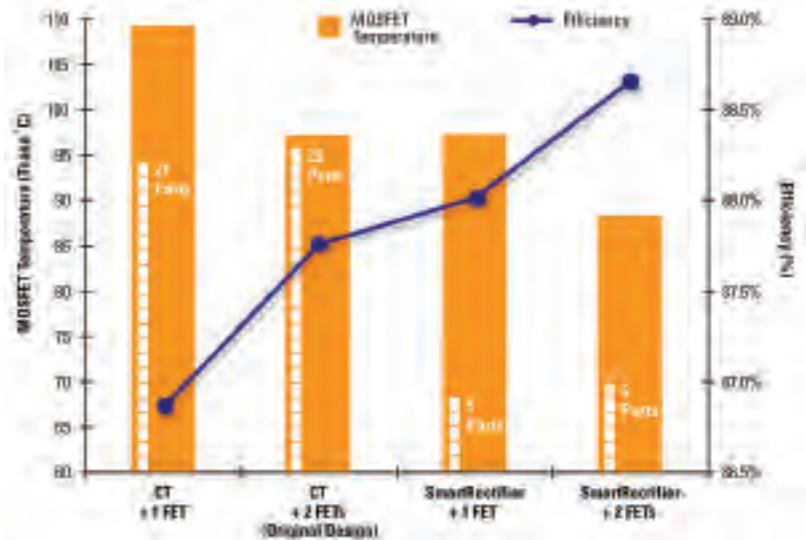

Flyback Example

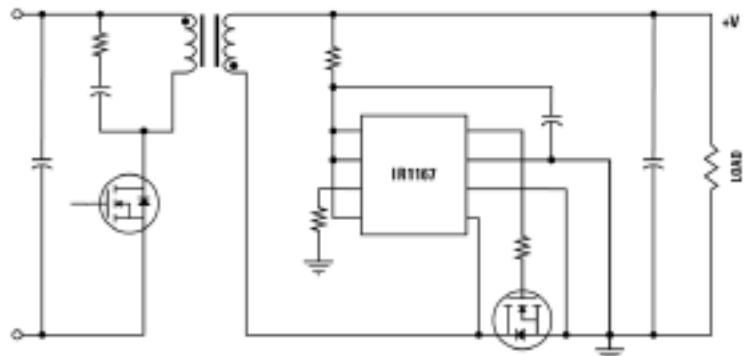

- 120W Laptop adaptor (19.5V, 6.15A) with current transformer (CT) and TO-220 SR FETs.
- Smart Rectifier shows 1% efficiency improvement
- 10°C lower FET temperature with same heatsinking.
- Allows reduction in SR FETs to allow system cost reductions.



The μ PFC™ Family of Controller ICs Radically Alters Traditional Thinking About PFC Solutions.

The IR1150 uses a new, patented "One-Cycle Control, integrator with reset" technique to deliver the high performance of Continuous Conduction Mode (CCM) PFC with the simplicity and low component count of Discontinuous Current Mode (DCM).

OCC does not have the traditional analog multiplier, AC line sensing or fixed oscillator ramp. In OCC the output of the error amplifier is integrated over each clock cycle to generate a variable-slope ramp. This variable ramp is compared with the error voltage and subtracted from the current sense signal to generate the PWM gate drive.

The IR1150 responds to changes in output voltage in just "one cycle" of the internal clock giving excellent response.

High Power (>200W) Systems

High power applications (>200W) need CCM PFC to have high efficiency and small system sizes. However, traditional CCM multiplier-based solutions are complex, require many design stages and have a high component count, making CCM solutions very expensive.

The IR Advantage

- Small, easy, powerful solution
- Enables high power density
- Fast time to market
- Enables compliance with PFC (THD) regulations for Japan, Europe, and China
- Enables compliance with energy standards (1W, Blue Angel, Energy Star)
- No AC line voltage sense required
- 0.999 power factor
- Programmable, fixed switching frequency, 50kHz to 200kHz
- Fast, powerful 1.5A peak gate drive
- Peak current mode control
- Dedicated OVP with soft start, brownout and output undervoltage protection
- Cycle by cycle peak current limit system protection
- For high power systems (>200W)
 - 40% fewer resistors and capacitors
 - Eliminates a current transformer
 - 50% smaller PCB area for the PFC control section
- For lower power systems (<250W)
 - Reduced peak currents
 - 40% reduction in EMI filter cost
 - 16% smaller PCB
 - 10% higher power density

Part Number	Package	V _{CC} (V)	I _O +/- (A)	Frequency (kHz)	T _{amb} (°C)	Environment	RoHS
IR1150STR	SO-8	13-22	1.5	50-200	0 to +70	Consumer	-
IR1150ISTR	SO-8	13-22	1.5	50-200	-25 to +85	Industrial	-
IR1150STRPbF	SO-8	13-22	1.5	50-200	0 to +70	Consumer	Lead Free
IR1150ISTRPbF	SO-8	13-22	1.5	50-200	-25 to +85	Industrial	Lead Free

Applications

- AC-DC smps >75W
 - Server SMPS & Telecom Rectifier
 - Notebook computers, LCD TVs, mini-PC power adapters
 - Plasma TVs, CRT monitors
 - High-end Set Top Boxes /PVRs, home theatre systems
 - Office machines such as photocopiers and printers
 - PC silver box power supplies
- Motor Drive / Pumps >75W
 - Washing machines, dish washers
 - Air conditioners
 - Pools, spas, well pumps

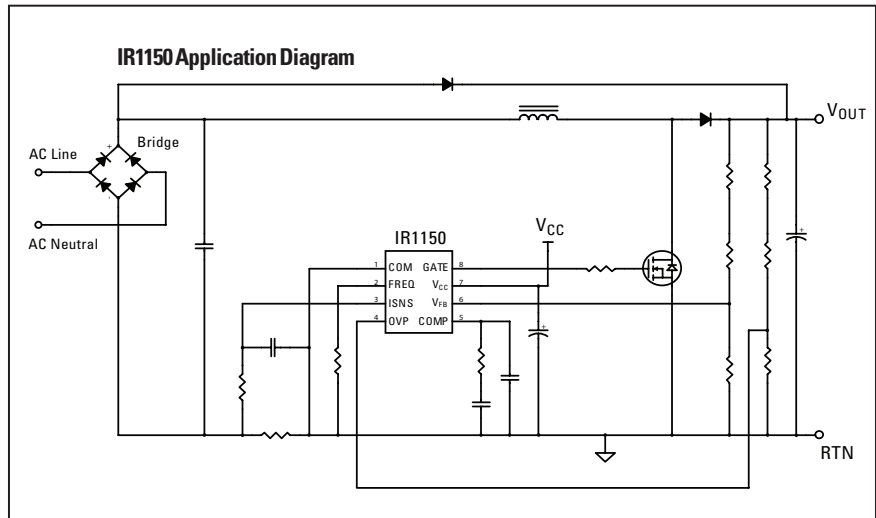

In a typical 1kW SMPS, the new OCC solution has 40% fewer resistors and capacitors, removes a current transformer and has a 50% smaller PCB area for the PFC control section. In addition, the IR1150 has a dedicated Over Voltage Protection (OVP) pin to give greater protection for high power systems.

Low Power (<250W) Systems

Lower power applications (<250W) traditionally use DCM systems for simplicity and low system cost. However, as system power increases to 100W and above – e.g. for high end laptop or LCD TV adaptors - DCM systems are large due to high peak currents and EMI filter requirements. OCC operates in CCM mode with reduced peak currents and a 43% reduction in EMI filter needs. This translates into a 16% reduction in PCB and an increase in power density of 10% for a typical 120W laptop adaptor.

Governmental & Energy Standards Compliance

The IR1150 includes features such as enable, micro-power start-up and "sleep mode" for compliance with energy efficiency standards such as "1W Standby", Blue Angel and Energy Star.

IR's OCC method used in the IR1150 is an attractive solution to PFC (THD) legislation such as IEC 1000-3-2 in Europe, JIS C 61000-3-2 in Japan and the China Compulsory Certificate (CCC) for products using more than 75W. PFC is not yet a requirement in the US, however, specifications are being prepared by the IEEE.

Even without the need to meet governmental legislation, PFC solutions using the IR1150 OCC IC offer two more advantages; a) designers can create one design with universal AC input for worldwide use which streamlines manufacturing, inventory and logistics, and b) PFC eliminates AC-line harmonics, reducing the rms current and so allows higher power motors or pumps to be used without tripping domestic circuit breakers.



Product Line Name **Class D Audio**

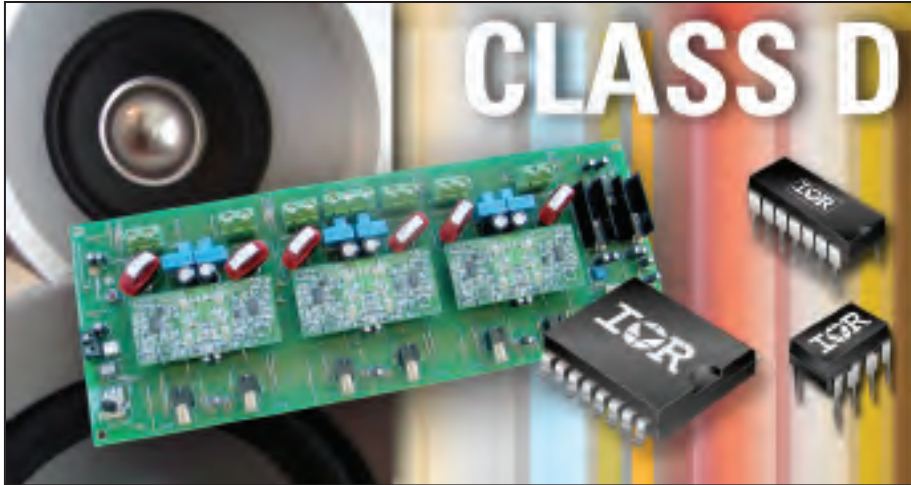

Gate Driver ICs

International Rectifier MOSFET driver ICs enable audio system manufacturers to efficiently design their Class D Audio amplifiers up to the 1000 watt level, with better sound quality. Audio components, from battery-powered portables to high-end multimedia systems can now be made more compact and operate with greater safety margins.

Audio Reference Designs

International Rectifier offers a complete class D audio power amplifier design, which contains protection functions and house keeping power supplies for ease of use. This reference design is intended to implement protection circuits and design an optimum PCB layout.

Features at a Glance:

IRAUDAMP3

Audio reference design for High Power Class D Audio Power Amplifier

- Developed specifically for Class D audio
- Integrated programmable dead time improves THD performance
- Integrated bi-directional lossless current sensing improves efficiency and simplifies design
- High speed propagation delay (70ns)
- 200V high voltage IC technology
- IRF6665 optimized for up to 100W, 6-8 Ohms
- IRF6645 optimized for up to 100W, 2-40ohms
- Lower package inductance reduces ringing, improves EMI performance
- Dual-sided cooling available for higher power

IR P/N	Description		
IRS2011(S)PbF	The IRS2011 is a high power, high speed power MOSFET driver with independent high- and low-side referenced output channels.		
IRS20124SPbF	The IRS20124S is a high voltage, high speed power MOSFET driver with internal dead-time and shutdown functions.		
IRS20955SPbF	The IRS20955 is a high voltage, high speed MOSFET driver with floating PWM input.		
Specifications	IRS2011(S)PbF	IRS20124(S)PbF	IRS20955(S)PbF
Offset Voltage	200V	200V	200V~ +/-100V
Sink/Source Current	1/1	1.2/1.0	1.2/1.0A
V _{CC} Range (with UVLO)	10-20V	10-18V	10-18V
Min/Max Output Voltage	10-20V	10-18V	10-18V
Propagation Delay: T _{ON/OFF}	60ns	85/70n	105/90ns
Max Delay Matchine	20ns	Specified by the dead time	Specified by the dead time
Programmability	IRS2011(S)PbF	IRS20124(S)PbF	IRS20955(S)PbF
Selectable Dead Time	-	15/25/35/45n	15/25/35/45ns
B-directional Over-Current Sensing with Self-Reset Function	-	-	●
Features	IRS2011(S)PbF	IRS20124(S)PbF	IRS20955(S)PbF
B-Directional Over-Current Sensing (no external sense resistor)	-	●	●
Max Frequency	1MHz	1MHz	800kHz
Logic Compatible Input	3.3/5.0	3.3/5.0	3.3/5.0V
Max Over-Current Propagation Delay	NA	300ns	600ns
Floating PWM Input	-	-	●
Max Power	500W	1000W	500W
Shut Down	-	●	internal/external
Protection Logic Control	-	-	●

Features

- Floating channel up to +1200V
- Monolithic integration
- Linear current feedback through shunt resistor
- Direct digital PWM output for easy interface
- Direct analog output for easy interface (IR2177 and IR2277 only)
- Independent fast over current trip signal
- High common mode noise immunity
- Input over voltage protection for IGBT short circuit condition
- Open drain outputs

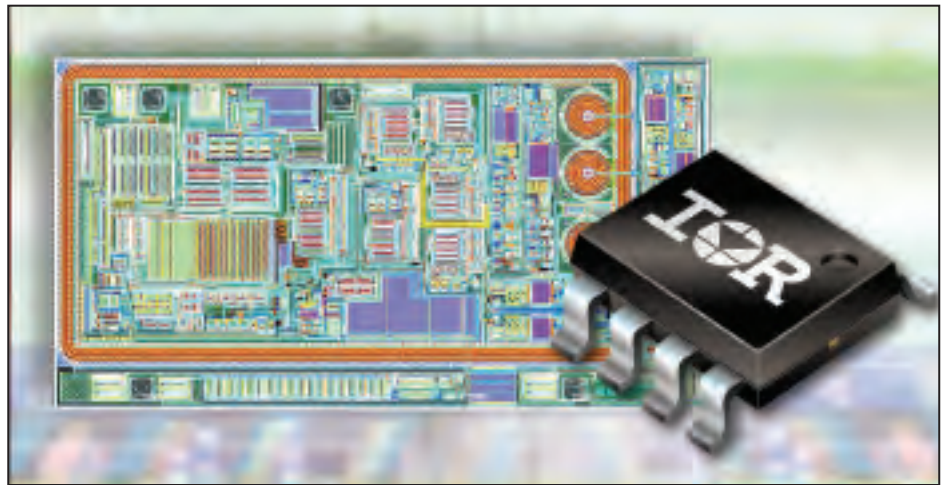

Motion Control Current Sensing ICs

The IR217x/IR227x is a family of monolithic current sensing ICs designed for motor drive applications. The ICs sense the motor phase current through an external shunt resistor, converts the current information from an analog to a digital signal, and transfers the signal to the low voltage circuitry. IR's proprietary high voltage isolation technology is implemented to enable the high bandwidth signal processing. The output format is either a discrete PWM to be used when A/D interface is not available or an accurate analog signal linked to an external voltage reference to simplify signal conditioning in A/D equipped applications. The dedicated over current trip signal facilitates IGBT short circuit and over current protection. The open-drain digital outputs of the IR2175, IR2177, IR2277, IR21771, and IR22771 make it easy for any interface from 3.3V to 15V. The self-adaptable analog output of the IR2177 and IR2277 make it easy to interface AD converter with any input range from 3V to 12.5V.

IR's iMOTION Integrated Design Platform delivers everything you need to design a complete variable speed motor control subsystem. From the front panel and power entry to the motor terminals, iMOTION brings powerful digital, analog and power silicon together with algorithms, development software and design tools.

Part Number	Package	Offset Voltage	PbF	Analog Output	Digital Output	Overcurrent Output	V _{IN} Range	Duty Cycle		V _{CC} Range
								Min	Max	
IR2175	8-Lead PDIP	600V	Yes	No	Yes	Yes	±260mV	7%	93%	9.5-20V
IR2175S	8-Lead SOIC									
IR2177S	16-Lead SOIC	600V	Yes	Yes	Yes	Yes	±250mV	10%	30%	8-20V
IR21771S	16-Lead SOIC	600V	Yes	No	Yes	Yes	±250mV	10%	30%	8-20V
IR2277S	16-Lead SOIC	600V	Yes	Yes	Yes	Yes	±250mV	10%	30%	8-20V
IR22771S	16-Lead SOIC	600V	Yes	No	Yes	Yes	±250mV	10%	30%	8-20V

Product Families **Digital Control ICs**

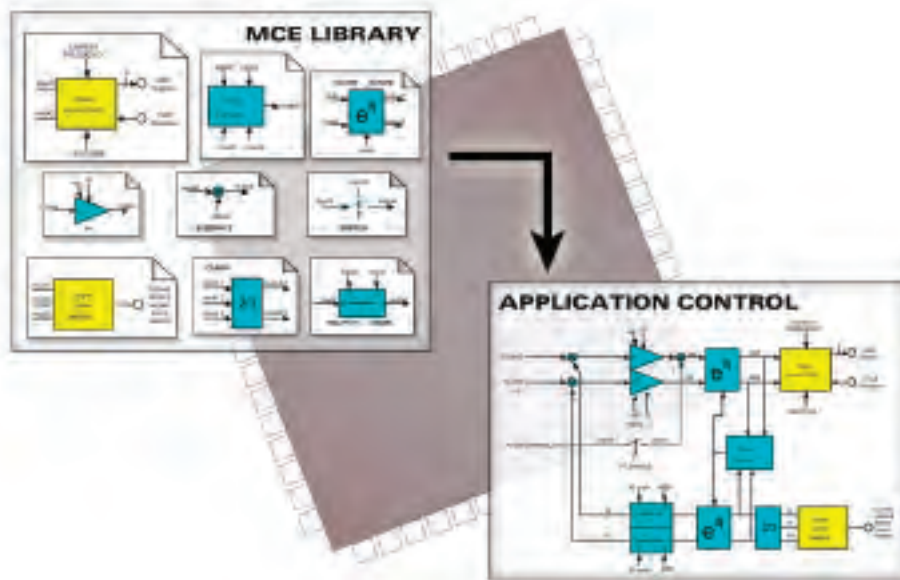

Applications

- In-room and wall air conditioners
- Washing Machines

Features

- Simultaneous sensor-less control for 2 PMSM motors and power factor correction
- Motion Control Engine eliminates control software coding
- Customer application code in co-integrated 60MIPs microcontroller

IR's iMOTION Integrated Design Platform Delivers Everything You Need

IR's iMOTION Integrated Design Platform delivers everything you need to design a complete variable speed motor control subsystem. From the front panel and power entry to the motor terminals, iMOTION brings powerful digital, analog and power silicon together with algorithms, development software and design tools. The latest iMOTION digital control ICs have been designed to include new features such as the microcontroller and embedded Analog Signal Engine™ together with the Motion Control Engine™ to enable simultaneous sensorless control of two Permanent Magnet motors and Power Factor Correction (PFC).

Advantages

- Simplifies design
- Speeds up development for faster time-to-market
- Eliminates need for external micro controller

Primary Application	Part Number	Package	Motor Control	Analog	Memory	I/O	Comms
Air Conditioners	IRMCF312	QFP100	2 Motors 1 PFC extra I/O and analog for system functions	12 bit A/D 11 channels POR UVLO Analog watchdog	48kByte Program RAM 8kByte Data RAM	36 dig I/O 1 Capture 4 Timers	RS232 x2 I2C/SPI
Air Conditioners	IRMCF311	QFP64	2 Motors 1 PFC Minimum set of pins for motor control	12 bit A/D 6 channels POR UVLO Analog watchdog	48kByte Program RAM 8kByte Data RAM	20 dig I/O 1 Capture 4 Timers	RS232 x2 I2C/SPI
Washers	IRMCF341	QFP64	1 Motor extra I/O and analog for system functions	12 bit A/D 8 channels POR UVLO Analog watchdog	48kByte Program RAM 8kByte Data RAM	24 dig I/O 1 Capture 4 Timers	RS232 I2C/SPI

HVIC Background Information

- High voltage integrated circuit (HVIC) drivers are driver ICs that receive an input signal from a control IC, amplify this signal, and drive one or more switches (MOSFET or IGBT)
- Many power conditioning applications (e.g., lighting, motor control, etc.) require one or more devices to be switched between high voltage rails; these applications require some form of high voltage level-shifting technology
- International Rectifier's proprietary high voltage level-shifting technology provides the required level-shifting for these applications in a compact, robust, and cost-effective design



High Voltage Gate Driver ICs (HVICs)

International Rectifier's MOSFET and IGBT gate driver ICs are the simplest, smallest and lowest cost solution to drive MOSFETs or IGBTs up to 1200V in applications up to 12kW, and can save over 30% in part count in a 50% smaller PCB area compared to a discrete opto-coupler or transformer based solution. With the addition of few external components, IR gate driver ICs provide full driver capability with extremely fast switching speeds, designed-in ruggedness and low-power dissipation.

Gate driver IC's generate the current and voltage necessary to turn MOSFETs or IGBTs on and off from the logic output of a DSP, micro-controller or other logic device. The input is typically a 3.3 volt logic-level signal. All IR gate driver ICs are CMOS compatible, and most are TTL compatible. Output currents are up to 2A.

IR Gate Driver ICs Simplify Design

Gate Driver IC driving a MOSFET or IGBT in the high side position of a half-bridge topology or 3 phase inverter leg offers the additional challenge that the gate voltage is referenced to the source rather than to ground. The source voltage is a floating point at up to the maximum bus voltage, or voltage rating of the MOSFET or IGBT, 600V and up for motor drive, lighting or SMPS applications. IR gate driver uses a patented level shifter technology for high voltage application and offers the only 1200V rating in the industry.

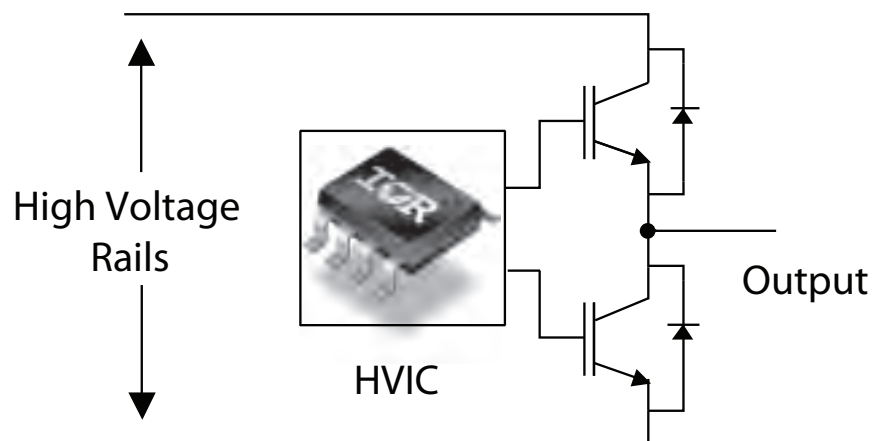

High Voltage ICs Product Families

	(units)	IRS2130(D)	IRS21303(D)	IRS2132(D)	IRS2133(D)	IRS2135(D)	IRS2136(D)	
Offset voltage	V	600	600	600	600	600	600	
General purpose input		Yes	Yes	Yes	Yes	Yes	Yes	
Matched prop. delay		Yes	Yes	Yes	Yes	Yes	Yes	
Programmable DT		No	No	No	No	No	No	
Hard shutdown	-	No	No	No	No	No	No	
Overcurrent SD (Itrip)		Yes	Yes	Yes	Yes	Yes	Yes	
SD Pin		No	No	No	Yes	Yes	No	
Integrated BS funct.		IRS2130D	IRS21303D	IRS2132D	IRS2133D	IRS2135D	IRS2136D	
INPUT LOGIC								
Logic compatibility	V	2.5	2.5	2.5	2.5	2.5	3.3	
HIN/N, LIN/N		Yes	Yes	Yes	Yes	Yes	Yes	
HIN, LIN/N	-							
OUTPUT								
V _{out}	V	10-20	13-20	10-20	10-20, 12-20	10-20, 12-20	10-20	
I _{Q+}	mA	250	250	250	250	250	200	
I _{Q-}		500	500	500	500	500	350	
UVLO								
V _{BSUV+} (positive going threshold)	V	8.35	11-13	8.35	8.6	10.4	8.9	
V _{BSUV-} (negative going threshold)		7.95	9-11	7.95	8.2	9.4	8.2	
V _{BSUVH} (hysteresis)		0.4	2	0.4	0.4	1	0.7	
V _{CCUV+} (positive going threshold)		9	11-13	9	8.6	10.4	8.9	
V _{CCUV-} (negative going threshold)		8.7	9-11	8.7	8.2	9.4	8.2	
V _{CCUVH} (hysteresis)		0.3	2	0.3	0.4	1	0.7	
TIMING								
t _{on}	ns	500	500	500	500	500	530	
t _{off}		500	500	500	500	500	530	
t _{sd}						550	550	
t _r		80	80	80	80	80	125	
t _f		35	35	35	35	35	50	
MT (delay matching)								50 (max)
DT (deadtime)			2000	700	700	230	230	290
MDT (deadtime matching)								60 (max)
t _{TRIP}			660	660	660	660	660	750
t _{SH}			400	400	400	400	400	400
t _{FLT}			550	550	550	550	550	600

	(units)	IRS21362(D)	IRS21363(D)	IRS21365(D)	IRS21366(D)	IRS21367(D)	IRS21368(D)	
Offset voltage	V	600	600	600	600	600	600	
General purpose input		Yes	Yes	Yes	Yes	Yes	Yes	
Matched prop. delay		Yes	Yes	Yes	Yes	Yes	Yes	
Programmable DT		No	No	No	No	No	No	
Hard shutdown	-	No	No	No	No	No	No	
Overcurrent SD (Itrip)		Yes	Yes	Yes	Yes	Yes	Yes	
SD Pin		No	No	No	No	No	No	
Integrated BS funct.		IRS21362D	IRS21363D	IRS21365D	IRS21366D	IRS21367D	IRS21368D	
INPUT LOGIC								
Logic compatibility	V	3.3	3.3	3.3	3.3	3.3	3.3	
HIN/N, LIN/N			Yes	Yes	Yes	Yes	Yes	
HIN, LIN/N	-	Yes						
OUTPUT								
V _{out}	V	11.5-20	12-20	12-20	12-20	12-20	10-20	
I _{Q+}	mA	200	200	200	200	200	200	
I _{Q-}		350	350	350	350	350	350	
UVLO								
V _{BSUV+} (positive going threshold)	V	10.4	11.1	11.1	11.1	11.1	8.9	
V _{BSUV-} (negative going threshold)		9.4	10.9	10.9	10.9	10.9	8.2	
V _{BSUVH} (hysteresis)		1	0.2	0.2	0.2	0.2	0.7	
V _{CCUV+} (positive going threshold)		10.4	11.1	11.1	11.1	11.1	8.9	
V _{CCUV-} (negative going threshold)		9.4	10.9	10.9	10.9	10.9	8.2	
V _{CCUVH} (hysteresis)		1	0.2	0.2	0.2	0.2	0.7	
TIMING								
t _{on}	ns	530	530	530	200	200	530	
t _{off}		530	530	530	200	200	530	
t _{sd}								
t _r		125	125	125	125	125	125	
t _f		50	50	50	50	50	50	
MT (delay matching)			50 (max)	50 (max)	50 (max)	50 (max)	50 (max)	50 (max)
DT (deadtime)			290	290	290	290	290	290
MDT (deadtime matching)			60 (max)	60 (max)	60 (max)	60 (max)	60 (max)	60 (max)
t _{TRIP}			750	750	750	750	750	750
t _{SH}			400	400	400	400	400	400
t _{FLT}			600	600	600	600	600	600

Product Families **High Voltage ICs**

The IR Advantage

- Dead-time as low as 500ns allows frequency up to 100kHz
- Increases speed range and torque control of motor drives
- Enable rugged gate drive design
- Low power dissipation
- Compared with opto-coupler based solutions:
- 30% fewer parts and 50% smaller PCB
- Doesn't need auxiliary power supply
- 10X faster delay matching ($\pm 50\text{ns}$)
- No degradation of performance over time
- Shorter time to signal over-current ($1.5\mu\text{s}$ versus $6\mu\text{s}$)
- Reduced EMI and voltage spikes

Applications

- Motor Drive
- Lighting Ballast
- Switched Mode Power Supplies
- Automotive
- Plasma Display Panels

Integrated Desat Protection

	(units)	Half-Bridge					3-Phase			
		IR2114	IR21141	IR2214	IR22141	IR21381	IR2233	IR2235	IR2238	IR22381
Offset voltage		600	600	1200	1200	600	1200	1200	1200	1200
Brake		No	No	No	No	Yes	No	No	Yes	Yes
General purpose comparator input		No	No	No	No	No	Yes	Yes	No	No
Programmable deadtime		No	No	No	No	Yes	No	No	Yes	Yes
Desat detection circuit	V	Yes	Yes	Yes	Yes	Yes	No	No	Yes	Yes
Active bias (desat)		No	Yes	No	Yes	Yes			No	Yes
Soft shutdown (desat)		Yes	Yes	Yes	Yes	Yes	No	No	Yes	Yes
Hard shutdown		Yes	Yes	Yes	Yes	Yes	Yes	Yes	Yes	Yes
Input logic for shutdown (SD Pin)		No	No	No	No	Yes	Yes	Yes	Yes	Yes
Logic Compatibility	V	2.5	2.5	2.5	2.5	2.5	2.5	2.5	2.5	2.5
HIN, LIN						Yes			Yes	Yes
HIN, LIN		Yes	Yes	Yes	Yes					
V_{out}	V	10.4-20	10.4-20	10.4-20	10.4-20	12.5-20	10-20, 12-20	10-20, 12-20	12.5-20	12.5-20
Output high short circuit pulsed current	mA	2000	2000	2000	2000	350	250	250	350	350
Output low short circuit pulsed current		3000	3000	3000	3000	540	500	500	540	540
V_{bs} UVLO positive going threshold	V	10.2	10.2	10.2	10.2	11.2	8.6	10.4	11.2	11.2
V_{bs} UVLO negative going threshold		9.3	9.3	9.3	9.3	10.2	8.2	9.4	10.2	10.2
V_{bs} UVLO hysteresis		0.9	0.9	0.9	0.9	1	0.4	1	1	1
V_{ce} UVLO positive going threshold		10.2	10.2	10.2	10.2	11.2	8.6	10.4	11.2	11.2
V_{ce} UVLO negative going threshold		9.3	9.3	9.3	9.3	10.2	8.2	9.4	10.2	10.2
V_{ce} UVLO lockout hysteresis		0.9	0.9	0.9	0.9	1	0.4	1	1	1
Turn-on propagation delay		440	440	440	440	550	750	750	550	550
Turn-off propagation delay		440	440	440	440	550	700	700	550	550
Shutdown propagation delay (SD Pin)						600	750	750	600	600
Turn-on rise time	ns	24	24	24	24	80	90	90	80	80
Turn-off rise time		7	7	7	7	25	40	40	25	25
Dead-time		330	330	330	330	100-5000	250	250	100-5000	100-5000
Dead-time matching (MDT)		75 (max)	75 (max)	75 (max)	75 (max)	125 (max)			145 (max)	125 (max)
High desat input threshold voltage	V	8	8	8	8	8			8	8
Low desat input threshold voltage		7	7	7	7	7			7	7
Desat input voltage hysteresis		1	1	1	1	1			1	1
High DSH or DSL input bias current	μA	21	21	21	21	15			15	15
Low DSH or DSL input bias current		-160	-160	-160	-160	-150			0.1	-150
DSH or DSL input bias current			-20		-20	-11.1				-11.1
BR output high short circuit pulsed current	mV					70			70	70
BR output low short circuit pulsed current						125			125	125
BR high level output voltage						6000			300	6000
BR low level output voltage						3000			150	3000

High Voltage ICs Product Families

Half-Bridge Drivers

	(units)	IRS2003	IRS2004	IRS2103	IRS2104	IRS2108	IRS21084	IRS2109	IRS21094	IRS2111	IRS2183	IRS21834	IRS2184	IRS21844	IRS2302	IRS2304	IRS2308	
Offset voltage	V	200	200	600	600	600	600	600	600	600	600	600	600	600	600	600	600	
Matched prop. delay		Yes	Yes	Yes	Yes	Yes	Yes	Yes	Yes	Yes	Yes	Yes	Yes	Yes	Yes	Yes	Yes	
Programmable DT	-	No	No	No	No	No	Yes	No	Yes	No	No	Yes	No	Yes	No	No	No	
SD Pin		No	No	No	Yes	No	No	Yes	Yes	No	No	No	Yes	Yes	Yes	No	No	
INPUT LOGIC																		
Logic compatibility	V	3, 3, 5, 15	3, 3, 5, 15	3, 3, 5, 15	3, 3, 5, 15	3, 3, 5, 15	3, 3, 5, 15	3, 3, 5, 15	3, 3, 5, 15	10-20	3, 3, 5	3, 3, 5	3, 3, 5	3, 3, 5	3, 3, 5, 15	3, 3, 5, 15	3, 3, 5, 15	
HIN, LIN/N		Yes		Yes							Yes	Yes						
HIN/N, LIN						Yes	Yes											
HIN, LIN								Yes	Yes							Yes	Yes	
IN			Yes		Yes					Yes			Yes	Yes	Yes			
OUTPUT																		
V _{out}	V	10-20	10-20	10-20	10-20	10-20	10-20	10-20	10-20	10-20	10-20	10-20	10-20	10-20	10-20	10-20	10-20	
I _{Q+}	mA	290	290	290	290	290	290	290	290	290	1900	1900	1900	1900	290	290	290	
I _{Q-}		600	600	600	600	600	600	600	600	600	2300	2300	2300	2300	600	600	600	
UVLO																		
V _{BSUV+} (positive going threshold)	V	-	-	-	-	8.9	8.9	8.9	8.9	8.6	8.9	8.9	8.9	8.9	4.1	8.9	8.9	
V _{BSUV-} (negative going threshold)		-	-	-	-	8.2	8.2	8.2	8.2	8.2	8.2	8.2	8.2	8.2	3.8	8.2	8.2	
V _{BSUVH} (hysteresis)		-	-	-	-	0.7	0.7	0.7	0.7	-	0.7	0.7	0.7	0.7	0.3	0.7	0.7	
V _{CCUV+} (positive going threshold)		8.9	8.9	8.9	8.9	8.9	8.9	8.9	8.9	8.6	8.9	8.9	8.9	8.9	4.1	8.9	8.9	
V _{CCUV-} (negative going threshold)		8.2	8.2	8.2	8.2	8.2	8.2	8.2	8.2	8.2	8.2	8.2	8.2	8.2	3.8	8.2	8.2	
V _{CCUVH} (hysteresis)		-	-	-	-	0.7	0.7	0.7	0.7	-	0.7	0.7	0.7	0.7	0.3	0.7	0.7	
TIMING																		
t _{on}	ns	680	680	680	680	220	220	750	750	750	180	180	680	680	750	150	220	
t _{off}		150	150	150	150	200	200	200	200	150	220	220	270	270	200	150	200	
t _{sd}		160	160	160	160			200	200				180	180	200			
t _r		70	70	70	70	100	100	100	100	75	40	40	40	40	100	70	100	
t _f		35	35	35	35	35	35	35	35	35	20	20	20	20	35	35	35	
MT (delay matching)		60 (max)	60 (max)	60 (max)	60 (max)			70 (max)	70 (max)	30	35 (max)	35 (max)	90/40	90/40		50 (max)		
DT (deadtime)		520	520	520	520	540	540-5000	540	540-5000	650	400	400-5000	400	400-5000	540	100	540	
MDT (deadtime matching)					60 (max)	60-600	60 (max)	60-600		50	50-600	50	50-600	60 (max)		60 (max)		

High-Low Drivers

	(units)	IR2213	IRS2001	IRS2101	IRS210(6,64)	IRS2110	IRS2112	IRS2113	IRS218(1,14)	IRS218(6,64)	IRS2301
Offset voltage	V	600	200	600	600	500	600	600	600	600	600
Matched prop. delay		Yes	Yes	Yes	Yes	Yes	Yes	Yes	Yes	Yes	Yes
SD Pin	-	Yes	No	No	No	Yes	Yes	Yes	No	No	No
Dual supply		No	No	No	No	Yes	Yes	Yes	No	No	No
INPUT LOGIC											
Logic compatibility	V	3, 3-20	3, 3, 5, 15	3, 3, 5, 15	3, 3, 5, 15	3, 3-20	3, 3-20	3, 3-20	3, 3, 5	3, 3, 5	3, 3, 5, 15
HIN, LIN	-	Yes	Yes	Yes	Yes	Yes	Yes	Yes	Yes	Yes	Yes
OUTPUT											
V _{out}	V	12-20	10-20	10-20	10-20	10-20	10-20	10-20	10-20	10-20	10-20
I _{Q+}	mA	2000	290	290	290	2500	290	2500	1900	4000	290
I _{Q-}		2500	600	600	600	2500	600	2500	2300	4000	600
UVLO											
V _{BSUV+} (positive going threshold)	V	10.2	-	-	8.9	8.6	8.5	8.6	8.9	8.9	4.1
V _{BSUV-} (negative going threshold)		9.3	-	-	8.2	8.2	8.1	8.2	8.2	8.2	3.8
V _{BSUVH} (hysteresis)		-	-	-	0.7	-	-	-	0.7	0.7	0.3
V _{CCUV+} (positive going threshold)		10.2	8.9	8.9	8.9	8.5	8.6	8.5	8.9	8.9	4.1
V _{CCUV-} (negative going threshold)		9.3	8.2	8.2	8.2	8.2	8.2	8.2	8.2	8.2	3.8
V _{CCUVH} (hysteresis)		-	-	-	0.7	-	-	-	0.7	0.7	0.3
TIMING											
t _{on}	ns	280	160	160	220	130	135	130	180	170	220
t _{off}		225	150	150	200	120	130	120	220	170	200
t _{sd}		230				130	130	130			
t _r		25	70	70	100	25	75	25	40	22	100
t _f		17	35	35	35	17	35	17	20	18	35
MT (delay matching)		30(max)	50 (max)	50 (max)	30 (max)	10 (max)	30 (max)	20 (max)	35 (max)	35 (max)	50 (max)

Product Families **iPOWIR™ Multi-Chip Modules**



Multi-chip modules, like the iPOWIR™ intelligent scalable buildingblocks integrate critical power, drive and control silicon, simplify design while raising the efficiency and current density of on-board power converters for the latest generation of low-voltage processors in single- and multi-phase topologies by. IR's expertise in device matching and "short trace" layout deliver this optimized solution that combines multiple power semiconductors, ICs, and passive components into a single package. The iPOWIR MCMs require less development effort than do discrete approaches.

Full Featured Devices Include:

- Overcurrent hiccup or latch mode
- External synchronization pin
- Independent soft start pins
- Overvoltage protection
- Overtemperature protection

Full Feature Device Applications:

- Non-isolated point-of-load buck converters:
- FPGAs & ASICs with dual logic (core & I/O)
- Peripheral Rails in close proximity (low power 15A)
- Single POL (mid power <30A)
- Distributed Power Architecture (DPA) or DC Bus converter 2nd stage POL converters

Features at a Glance:

Full featured: All power semiconductors and analog control & driver IC integrated in one solution to complete a synchronous buck converter

Multiphase: All the power semi-conductors and analog driver ICs to complete a power stage for a multiphase buck converter.

iPOWIR™ benefits

- Reduces part count up to 90%
- Very small form factor, up to 60% smaller than discrete equivalent
- Single phase single output, dual output and multiphase options
- Internal features minimize layout sensitivity
- Reduced time to market
- Guaranteed power loss

Full-featured iPOWIR™ Device

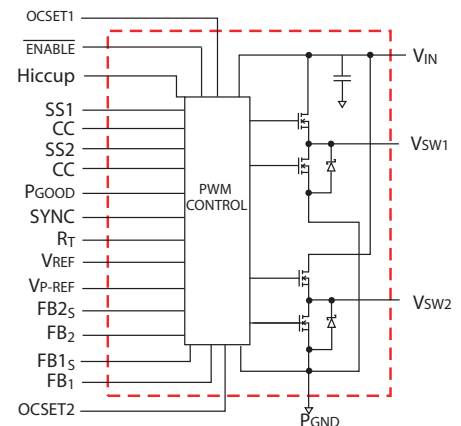

Full Feature power block

Part Number	Package	V _{IN} (min/max)	V _{OUT}	I _{OUT} -Double sided heatsinking	I _{OUT} -Single sided heatsinking	Frequency
ip1201	BGA 9.25 mm x 15.5mm x 2.6 mm	3.14V - 5.5V	0.8V-2.5V for 3.3V _{IN} 0.8V-3.3V for 5V _{IN}	15A dual 30A single	11.5A dual 23A single	200 - 400kHz
ip1202	BGA 9.25 mm x 15.5mm x 2.6 mm	5.5V - 13.2V	0.8V-5V for 12V _{IN} 0.8V-3.3V for <6V _{IN}	15A dual 30A single	11.5A dual 22A single	200 - 400kHz
ip1203	LGA 9 mm x 9 mm x 2.3 mm	5.5V - 13.2V	0.8V-8.0V for 12V _{IN}	15A dual	11A dual	200 - 400kHz

iPOWIR™ Multi-Chip Modules Product Families

Multiphase Devices Include:

- Up to 40A capability
- 300-1000 kHz frequency
- Up to 92% efficiency

Multiphase Applications:

- High-current multiphase synchronous buck converters to power CPUs in server and esktop computing
- Network processing units (NPU) and application-specific ICs (ASICs) used in net-working, telecom switchers and routers

Multiphase iPOWIR™ Power Stage

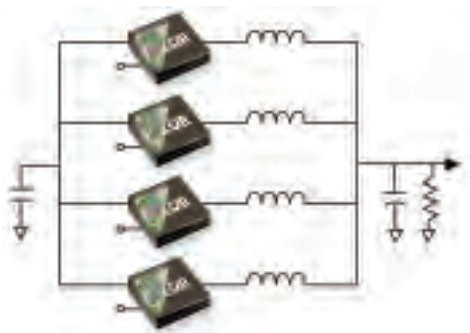
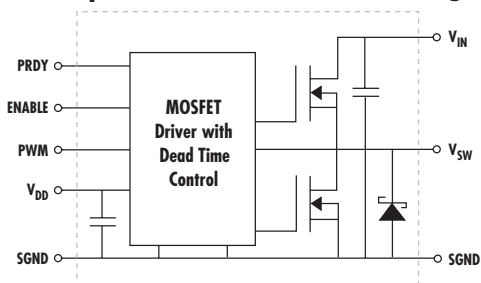

The iP200x series family is a functional “building block” for multiphase buck converters which are used to power GHz class CPUs in high-end computing and communications systems. Based on International Rectifier’s *iPOWIR*™ technology, the iP200x integrates the power semiconductors, a driver IC and layout-critical passives required for each phase of a multiphase synchronous buck converter into a single package. These products are offered in either ball grid array (BGA) or land grid array (LGA).

GHz class CPUs and high end ASICs require lower voltages, higher currents and faster transient response, all this in reduced solution footprints. By increasing switching frequency, the external passives can be reduced in size and quantity and transient response can be improved. However, increased emphasis on power density and higher operating frequencies can lead to greater layout challenges and higher parasitic losses.

The *iPOWIR* technology platform at International Rectifier capitalizes on proprietary lead-less multi-chip packaging, opening the doors to new levels in power density and enabling the performance required by future converters. The *iPOWIR* technology is an example of IR’s power management expertise in all areas and is much more than simply integrating functions. Benchmark power semiconductors are matched with control ICs, optimized packaging and advanced system design. Only when all of these aspects are combined can complete functionality be bundled into a tiny, easy to design solution.

Integration reduces parasitic losses enabling the iP200x to achieve higher efficiency at full-load, while the tiny BGA and LGA packages helps reduce solution footprint. Design time and effort are reduced because one iP200x device replaces up to 10 discrete components per phase, significantly reducing part count. The iP200x requires only a multiphase PWM IC, input and output capacitors and output inductors to enable the design of a fully functional mutiphase buck converter.

Multiphase power block

Part Number	V _{IN}	V _{DD}	V _{OUT}	I _{OUT} (max)	Frequency	Package
iP2001	5-12	5V	0.9-3.3V	20A	250-1000kHz	11mm x 11mm x 3mm BGA
iP2002	2.5-12	5V	0.9-3.3V	30A	250-1000kHz	11mm x 11mm x 2.6mm BGA
iP2003A	3-13.2	5V	0.8-3.3V	40A	300-1000kHz	11mm x 9mm x 2.2mm LGA

Product Families **Fluorescent Lighting ICs**

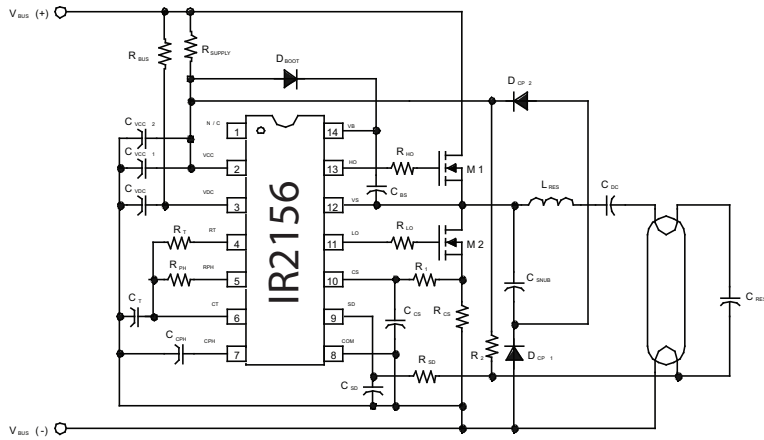

Fluorescent Lighting

Fluorescent lighting is used everywhere in our day-to-day lives, from consumer lighting to architectural lighting. High Voltage ICs are an integral part of electronic ballasts, and IR has a product offering to match your requirements.

For Example, Fluorescent Ballast ICs feature:

- **Dimming and Non-Dimming Versions**
- **Handle all lamp types**
- **Easy design, minimize component count**

Fluorescent Lighting Solutions

IR P/N	Description
IRS2153D	The IRS2153D is an improved version of the popular IR2153 gate driver IC, and incorporates an internal bootstrap diode as well as a 2V under-voltage lockout hysteresis.
IRS21531D	IRS21531D is a modified version of IRS2153D with smaller deadtime to reach higher frequencies.
IR2520D	600V Ballast Controller IC with Adaptive Zero-Voltage Switching, Internal Crest Factor Over-Current Protection and an Integrated Bootstrap Diode in a 8-Pin Dip package.
IR2156	High voltage half-bridge gate driver with a programmable oscillator and state diagram to form a complete ballast control IC including programmable features and built-in protection.
IR21571	Fully integrated, fully protected 600V ballast control IC designed to drive fluorescent and HID Lamps.
IRS2166D	The IRS2166D is a next-generation fully integrated, protected 600V ballast control IC designed to drive fluorescent and HID lamps with PFC in a 16-pin package.



Programmability	IRS2153D	IRS21531D	IR2520D	IR2156	IR21571	IRS2166D
Preheat Time	-	-	•	•	•	•
Preheat Frequency	-	-	•	•	-	-
Run Frequency	-	-	-	-	•	•
Ignition Ramp	•	•	•	•	•	•
Deadtime	-	-	•	•	-	•
Features	IRS2153D	IRS21531D	IR2520D	IR2156	IR21571	IRS2166D
Fixed Deadtime	1.1µs	0.6µs	1.5µs	-	-	-
Adaptive ZVS (zero voltage switching)	-	-	•	-	-	-
Over-current Protection	-	-	•	•	•	•
Under-current Protection	-	-	-	-	•	•
Failure to Strike	-	-	•	•	•	•
Open Filament	-	-	•	•	•	•
Below resonance protection	-	-	•	-	•	•
Brownout Protection	-	-	•	-	•	•
Thermal Overload Protection	-	-	-	-	•	-
Automatic re-start	-	-	•	•	•	•
Shutdown Pin	* (•)	* (•)	-	•	•	•
Adjustable over-current protection	-	-	-	•	•	•
Dimming	-	-	-	-	-	-
Ignition Detection	-	-	-	-	-	-
Fault Counter	-	-	•	-	-	•
End-of-Life Protection	-	-	•	-	-	•
VCO	-	-	•	-	-	-
Integration	IRS2153D	IRS21531D	IR2520D	IR2156	IR21571	IRS2166D
Bootstrap Diode	•	•	•	-	-	•
PFC (power factor corrector)	-	-	-	-	-	•
Current Sensing using VS sensing	-	-	•	-	-	-
Package	IRS2153D	IRS21531D	IR2520D	IR2156	IR21571	IRS2166D
DIP & SOIC	8pin	8pin	8pin	14pin	16pin	16pin

* Non latch shutdown

International Rectifier ICs are designed to meet the ballast load requirements for most applications, from real life to abnormal conditions.

IRS2540

- 200V half-bridge driver IC
- Micropower startup (<500mA)
- 3% voltage reference
- 140ns deadtime
- 15.6V Zener clamp on VCC
- Frequency up to 500 kHz
- Auto restart, non latched shutdown
- PWM dimmable

IRS2541

- 600V half-bridge driver IC
- Micropower startup (<500mA)
- 3% voltage reference
- 140ns deadtime
- 15.6V Zener clamp on VCC
- Frequency up to 500 kHz
- Auto restart, non latched shutdown
- PWM dimmable



LED Lighting Solution 3

HB-LEDs feature huge longevity, low maintenance requirement, small size, design flexibility, decorative effect capability, safe low DC voltage operation, excellent cold weather performance, lack of mercury, superior color gamut and brightness are making LEDs extremely popular. IR offers dedicated control ICs which can use at best all the LEDs features either in a DC-DC environment or directly off-line. Furthermore IR ICs offers a high degree of integration, minimizing the design time needed and increasing system reliability.

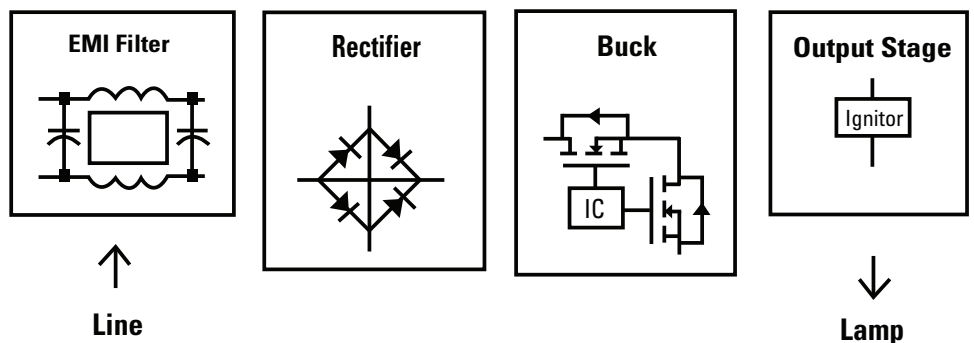

Specifications:

Part Number	Package	Voltage	load current regulation	Micro-power Start-up	Deadtime	Frequency
IRS2540xPbF	DIP8,S08	200	+/-5%	<500 μ A	140ns	<500kHz
IRS2541xPbF	DIP8,S08	600	+/-5%	<500 μ A	140ns	<500kHz

Halogen Lighting ICs Product Families

Halogen Lighting ICs

IR P/N	Description
IRS2153D	The IRS2153D is an improved version of the popular IR2153 gate driver IC, and incorporates a internal bootstrap diode as well as a 2V under voltage lockout hysteresis.
IR2161	Halogen Converter Control IC in a 8-lead PDIP package, Features Auto Resetting Short Circuit Protection, Auto Resetting Overload Protection, Overtemperature Protection, Phase Cut Dimmable, Adaptive Deadtime, Output Voltage Shift Compensation and Softstart.

Programmability	IRS2153D	IR2161
Run Frequency	YES	-
Features	IRS2153D	IR2161
Soft Start	-	●
Fixed Deadtime	1.1µs	-
Adaptive Deadtime	-	●
Over-Current Protection	-	●
Adjustable Over-current	-	●
Thermal Overload	-	●
Auto-resetting Short Circuit Protection	-	●
Auto-resetting Overload Protection	-	●
Frequency wobble for better EMI	-	●
Frequency shift Output Voltage Regulation	-	●
Integration	IRS2153D	IR2161
Bootstrap Diode	YES	-
Package	IRS2153D	IR2161
DIP & SOIC	8 pin	8 pin

Product Families **HID Lighting Solutions**



HID Lighting Solutions

Thanks to key advantages over other light sources (high lumen output, long life, color rendering and “point of light”), HID lamps are gaining in popularity in the industrial world. From few tens of watts for shop lights, to several hundreds of watts for street lighting, IR ICs offer a high degree of integration, minimizing the design time needed and increasing ballast reliability. The traditional industrial topology includes a PFC front-end, a buck converter to regulate the current, and a full bridge switching a 50% inverting the polarity.

PFC Front End

IR1150: The IR1150 uses a new, patented “One-Cycle Control, integrator with reset technique to deliver the high performance of Continuous Conduction Mode (CCM) PFC with the simplicity and low component count of Discontinuous Current Mode (DCM).

Buck Stage

IRS2117/18: single high side driver, that allows an easy single drive (1 switch).

IRS21844: thanks to its programmable dead time as well as high current capability (1,5A), the IRS21844 eases the design of a synchronized buck (2 switches) for high power ranges.

Full bridge

IRS2453D: a self-oscillating full bridge driver with 50% duty cycle, that replaces synchronized IRS2153D.

IRS2101, IRS2109, IRS2104, IRS2308:

If the control circuitry provides the PWM signals, one of IR’s robust high and low side or half-bridge drivers can also be used, depending on drive current capabilities.

LIGHTING HID

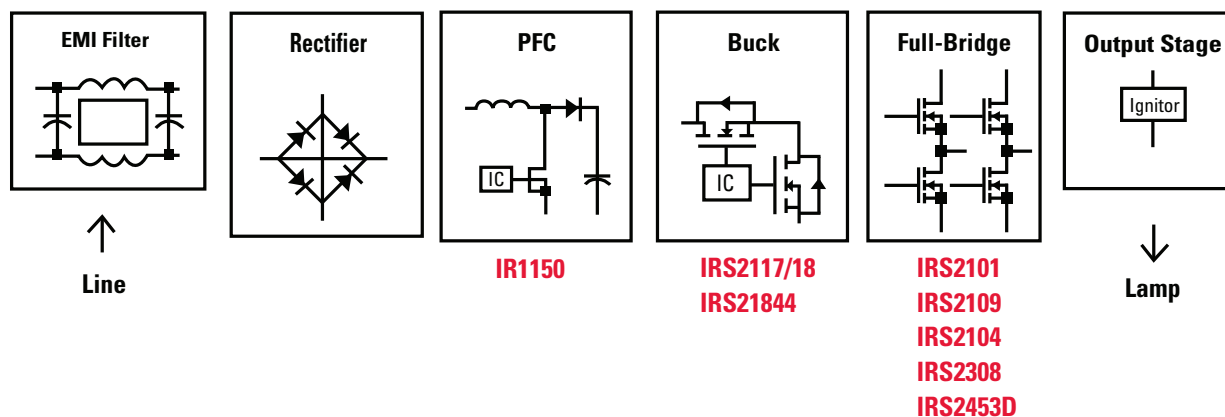

HID Lighting ICs

Buck Stage	Description
IRS2117/18	Single high side driver, that allows an easy single drive (1 switch).
IRS21844	Thanks to its programmable dead time as well as high current capability (1,5A), the IRS21844 eases the design of a synchronized buck (2 switches)

Full Bridge	Description
IRS2453D	A self-oscillating full bridge driver with 50% duty cycle, that replaces 2x IRS2153D: two synchronized half-bridge drivers, used in a full bridge configuration. If the control circuitry provides the PWM signals, one of IR's robust high and low side or half-bridge drivers like IRS2101, IRS2109, IRS2104, IRS2308 can also be used, depending on drive current capabilities as well as topology.

IR P/N	Description - PFC Stage
IR1150	Continuous conduction mode PFC controller
IR P/N	Description - Buck Stage
IRS2117	Single high side driver, 600V - 200 / 400mA
IRS21844	Half-bridge driver, 600V 1.9 / 2.3A
IR P/N	Description - Full Bridge Stage
IRS2453D	Self-oscillating full bridge driver with 50% duty cycle, 600V - 180 / 260mA
IRS2101	High and low side driver, 600V - 130 / 270mA
IRS2308	High and low side driver, 600V - 200 / 350mA
IRS2104	Half-bridge driver - 600V, 130 / 270mA - SD
IRS2109	Half-bridge driver - 600V, 120 / 250mA - SD - VBS UVLO

Product Families **Switching Regulators DC-DC**



Voltage regulators provide clean regulated voltages to various loads such as micro-processors, micro-controllers, memory chips, low voltage logic circuits and drivers while offering protection and filtering from electrical transients and noise. International Rectifier offers two types of regulators:

Features at a Glance

PWM Controller ICs:

- Single or multiphase topology
- Current sharing for design flexibility (IR3621)
- On-chip MOSFET drivers

The IR Advantage

- One source for voltage regulator ICs and power semiconductors
- Combine with IR HEXFET® power MOSFETs for high-efficiency solution

Applications

- Desktops & Servers
- DDR memory
- Networking and telecom
- Consumer electronics
- Graphics Cards

DC - DC Controllers

Part Number	Description	Package	Vcc (Min)	Vcc (Max)	Vout (Min)	Vout (Max)	Iout (A)	Application
IRU3138	Tracking PWM Controller	14 pin SOIC	4	25	0.8	Vcc*0.9	25	DDR memory
IRU3037	Sync PWM Controller	8 Pin SOIC 8 Pin TSSOP	4	25	1.25	Vcc*0.96	20	I/O Power, LCD TV
IR3092	2 Phase VR10 AMD control IC	48L MLPQ	7.3	21	0.8	1.85	80	VR10, Opteron, Athlon
IR3093	3 Phase VR10 AMD control IC	48L MLPQ	7.4	21	0.8	1.85	120	VR10, Opteron, Athlon
IR3094	3 Phase PWM Controller	48L MLPQ	7.4	21	0.85	5	120	High Current 3 phase POL
IR3623	Dual Channel Controller	32L MLPQ 5X5	8.4	16	0.8	Vcc*0.85	20	High Density 20 POL
IR3637	Sync PWM Controller	8 pin SOIC	4	16	0.8	Vcc*0.85	20	DDR memory, graphics card
IR3637A	Sync PWM Controller	8 pin SOIC	4	16	0.8	Vcc*0.85	10	STB
IR3621	Dual Sync PWM or 2 phase single output with pre-bias	28 Pin TSSOP 32L MLPQ 5X5	5.3	16	0.8	Vcc*0.9	60	High current 2 phase POL Dual Output Regulator
IR3065	Positive to Negative DC-DC controller	6 Pin SOT-23	4	7	-30	---	1	Application requires negative voltage less than 500mA
IR3624	DWM Controller with pre-bias	10L MLPQ	4	1.4	0.6	Vcc*0.71	10	ASIC, FPGA

* Lead free versions available. Please visit www.irf.com for complete lists.

XPhase® Multiphase Architecture Product Families

Features at a Glance

Control ICs

- Support both VR11 & 8bit VID and extended VR10 7bit VID Code
- 5-bit AMD Opteron™ compatible VID
- Programmable dynamic VID slew rate
No discharge of output capacitors during dynamic VID step-down (can be disabled)
- Programmable 150kHz to 1MHz oscillator
- Programmable voltage positioning
- Programmable softstart
- Programmable hiccup over-current protection with delay to prevent false triggering
- Simplified powergood provides indication of proper operation and avoids false triggering
- Operates from 12V input.
IR3082A from 9.5V input
- 6.8V/5mA bias regulator provides system reference voltage
- Enables input

Phase ICs

- 2.5A average gate drive current
- Loss-less inductor current sense
- Internal inductor DCR temperature compensation
- Programmable phase delay
- Programmable feed-forward voltage mode PWM Ramp
- 1MHz per-phase operation
- Current sense amplifier drives a single wire average current share bus
- Current share amplifier reduces PWM ramp slope to ensure sharing between phases
- Body braking disables synchronous MOSFET for improved transient response and prevents negative output voltage at converter turn-off
- OVP comparator with 100ns response (not included in IR3088A)
- Phase fault detection (Optiphase™ in IR3087)
- Programmable phase over-temperature detection

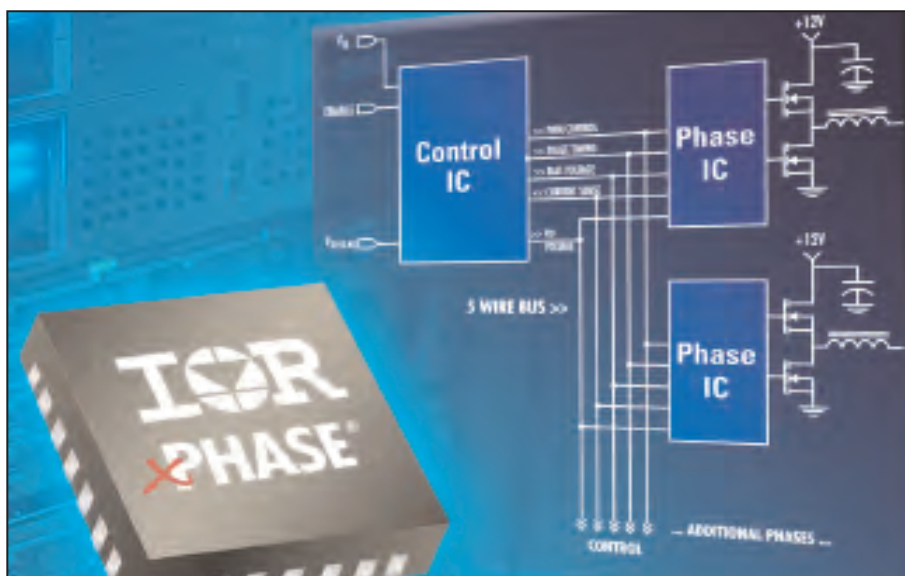

The Scalable, Flexible Multiphase Architecture

Take your interleaved DC-DC buck converter designs to market faster with groundbreaking XPhase® architecture from International Rectifier. The XPhase chip set consists of the control IC, containing all the one-per-converter circuitry, and a scalable array of phase converters, each using a single phase IC with all the one-per-phase circuitry.

Applications

- Voltage regulators for CPUs in workstations and servers
- High current NPUs in networking equipment

Awards

- XPhase Chip Set Wins EDN Innovation of the Year Award
- XPhase Wins Electronic Products Magazine Product of the Year Award

The IR Advantage

- Offers unprecedented flexibility and scalability to support one-to-X phase operation.
- Incorporates unique body braking to achieve dramatic improvements in transient response time while improving efficiency.
- Implements novel control and average output inductor current sensing to accomplish very accurate current sharing with support for 100% duty cycle and over-lapping phases. In addition, it supports single cycle transient response.

Part Number	Function	Package	Package Size	Applications
IR3082	AMD Opteron™ Control IC	20-lead MLPQ	5mm x 5mm	Controller for AMD Opteron based servers
IR3082A	9.6V AMD Opteron™ Control IC	20-lead MLPQ	5mm x 5mm	Controller for AMD Opteron based servers
IR3084	VR10, VR11 Control IC	28-lead MLPQ	4mm x 4mm	Controller IC for VR10, VR11
IR3084U	VR10, VR11 Control IC	28-lead MLPQ	4mm x 4mm	Controller IC for VR10, VR11 for AMD Opteron
IR3086A	Phase IC with integrated phase fault detect and VR-HOT	20-lead MLPQ	4mm x 4mm	Phase IC industrial PCs, workstations and servers
IR3087	Phase IC with integrated VR-HOT and Optiphase™ technology	20-lead MLPQ	4mm x 4mm	Suitable for applications which require ability to turn off phases for improved light load efficiency
IR3088A	Phase IC with integrated VR-HOT and phase fault detect	20-lead MLPQ	4mm x 4mm	Suitable for applications requiring output voltages up to 5V

Product Families IGBTs Discrete Motion

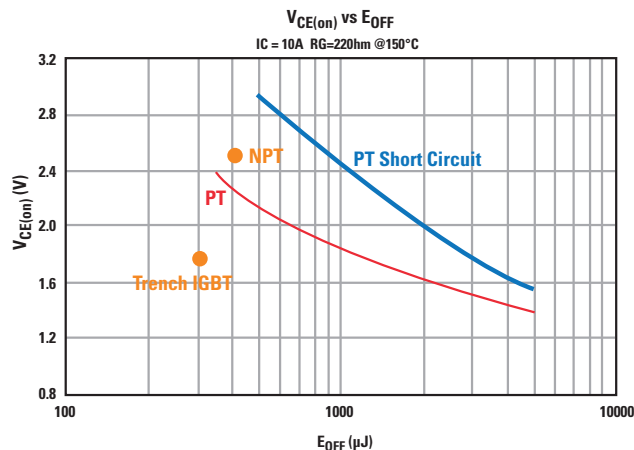

Features at a Glance

- Highly efficient depletion-stop trench IGBTs in range of configurations including discrete and integrated modules
- Lower collector-to-emitter saturation voltage, V_{CE(ON)} plus total switching loss, ETS than punch-through (PT) and non-punch-through (NPT) IGBTs

Benchmark 600V Trench IGBTs

IR's extensive range of highly efficient depletion-stop trench IGBTs are offered in a wide range of configurations, including discrete and integrated modules.

These Trench IGBTs have lower collector-to-emitter saturation voltage, V_{CE(ON)} and total switching loss, ETS than punch-through (PT) and non-punch-through (NPT) IGBTs.

IR's iMOTION Integrated Design Platform delivers everything you need to design a complete variable speed motor control subsystem. From the front panel and power entry to the motor terminals, iMOTION brings powerful digital, analog and power silicon together with algorithms, development software and design tools.

Trench IGBT Co-Pack

Part Number	Package	Circuit	I _C @25°C	I _C @100°C	V _{CE(on)} @25°C
IRGB4056D	TO-220	Co-Pack	24.0A	12.0A	1.85V
IRGB4061D	TO-220	Co-Pack	36.0A	18.0A	1.95V
IRGB4062D	TO-220	Co-Pack	48.0A	24.0A	1.95V
IRGP4062D	TO-247	Co-Pack	48.0A	24.0A	1.95V

NPT IGBT Co-Pack

Part Number	Package	Circuit	I _C @25°C	I _C @100°C	V _{CE(on)} @25°C
IRGR3B60KD2	D-Pak	Co-Pack	7.8A	4.2A	1.9V
IRG*4B60K	TO-220AB, D ² Pak, TO-262	Co-Pack	12A	6.8A	2.1V
IRG*4B60KD1	TO-220 Full-Pak, D ² Pak, TO-262	Co-Pack	12A	6.8A	2.1V
IRG*6B60KD	TO-220AB, D ² Pak, TO-262	Co-Pack	13A	7A	1.8V
IRG*8B60K	TO-220AB, D ² Pak, TO-262	Co-Pack	17A	9A	1.8V
IRG*10B60KD	TO-220AB, D ² Pak, TO-262	Co-Pack	22A	12A	1.8V
IRG*15B60KD	TO-220AB, D ² Pak, TO-262	Co-Pack	31A	15A	1.8V
IRGIB6B60KD	Isolated TO-220 Full-Pak	Co-Pack	9A	6A	1.8V
IRGIB7B60KD	Isolated TO-220 Full-Pak	Co-Pack	12A	8A	1.8V
IRGIB10B60KD1	Isolated TO-220 Full-Pak	Co-Pack	16A	10A	1.7V
IRGIB15B60KD1	Isolated TO-220 Full-Pak	Co-Pack	19A	12A	1.8V

NPT IGBT Discrete

Part Number	Package	Circuit	I _C @25°C	I _C @100°C	V _{CE(on)} @25°C
IRG*6B60K	TO-220AB, D ² Pak, TO-262	Discrete	13A	7A	1.8V
IRG*30B60K	TO-220AB, D ² Pak, TO-262	Discrete	78A	50A	1.95V

IGBTs Discrete Power Supply Product Families

Features at a Glance

- NPT technology, positive temperature coefficient
- Lower $V_{CE(SAT)}$
- Lower parasitic capacitances
- Minimal tail current
- HEXFRED ultra-fast soft recovery Co-Pack diode
- Tighter distribution of parameters
- Higher reliability

The IR Advantage

- Parallel operation for higher current applications
- Lower conduction losses and switching losses
- Higher switching frequency up to 150kHz

Applications

- Telecom and server SMPS
- PFC and ZVS SMPS circuits
- Uninterruptible power supplies
- Consumer electronics power supplies

WARP2™ series of Thin Wafer IGBTs for High Frequency SMPS Applications

The WARP2 series of 600V devices (20A, 35A and 50A) in Non Punch Through (NPT) IGBT family are targeted towards high frequency SMPS applications. With a small tail current and a low turn off energy E_{off} , the devices enable the converter to operate up to 150kHz, the range currently dominated by Power MOSFETS. All WARP2 IGBTs are offered with co-pack HEXFRED diodes, which offer excellent reverse recovery characteristics, much better than the integral diodes in a Power MOSFET.



The improvement in switching performance, combined with the positive thermal coefficient characteristics and the lower gate turn-on charge Q_g , allows these devices to operate efficiently up to 150kHz, while offering excellent current sharing properties when operated in parallel, like power MOSFETS. Unlike Power MOSFETS, the conduction losses of these IGBTs remain essentially flat.

These features make the WARP2 IGBTs an excellent choice. in SMPS applications for medium and large power SMPS designs in Telecom and Computer systems.

System Efficiency Comparison in a 2000W Power Supply

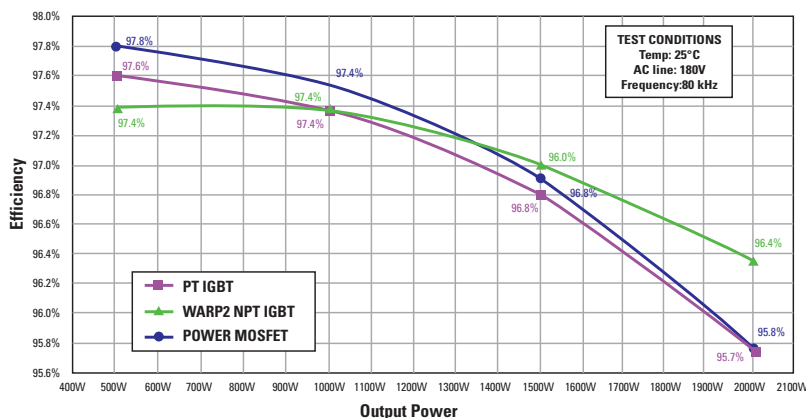

Voltage Drop vs. Current

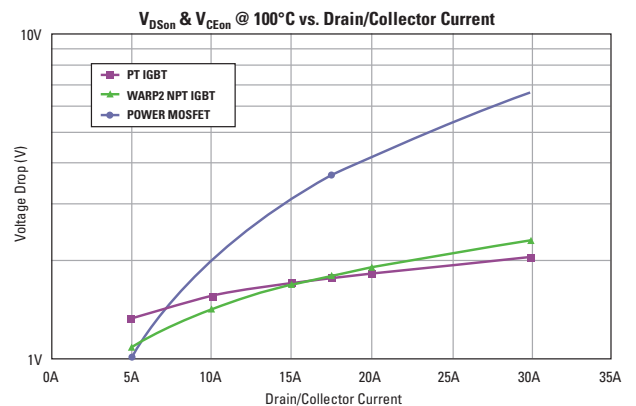

WARP2 IGBT Part Number	Package	V_{CES}	I_C at 25°C	$V_{CE(on)}$ typ.	Co-Pack Diode	Q_g
IRGP50B60PD1	TO-247	600V	50A	2.0V@33A	15A	205nC
IRGP35B60PD	TO-247	600V	35A	1.85V@22A	15A	160nC
IRGP20B60PD	TO-247	600V	20A	2.05V@13A	8A	68nC
IRGB20B60PD1	TO-220	600V	20A	2.05V@13A	4A	68nC

Product Families **Intelligent Power Modules**

High voltage power stage delivers dedicated, reliable appliance solution

Integrating industry benchmark three-phase high voltage ICs and rugged trench IGBTs in a sleek and innovative single in-line package (SIP), IR's intelligent power modules (IPMs) deliver a complete power stage solution for today's energy-efficient appliance and light industrial equipment driven by variable speed motors ranging from 400W to 2500W.



The IPMs are an addition to the iMOTION™ family of integrated design platforms from IR. Together with a few external components and our IRMCK series of controllers, they form a complete motor drive system, greatly accelerating the design path compared to a multi-discrete solution. Built-in over-temperature/over-current protection, along with short-circuit rated IGBTs, an integrated under-voltage lockout function, and built-in temperature monitor provide a high level of protection and fail-safe operation. Other integrated features, such as bootstrap diodes for the highside drive function and the single polarity power supply, simplify overall system design.

Features at a Glance

- Utilizes proprietary three-phase monolithic gate driver IC matched with highly efficient IGBT power switches
- Insulated metal substrate technology for reduced EMI
- Optimized for power up to 2.2kW
- Web-based design tool at www.irf.com/design-center/ipm
- Replaces more than 20 discrete parts to deliver complete power stage solution
- Shrinks board space requirements
Shortens design time
- Slashes assembly time and cost
- Boosts reliability over discrete designs
- No additional isolation required
- Simplifies procurement and inventory management
- Reference design kit available

Applications

- Clothes Washers
- In-room and wall air-conditioners
- Compressor drives
- Appliance fans/compressors
- Light industrial drives

Main Configuration

- Open emitter configuration: flexible architecture to configure current sensing feedback resistors. Over-temperature is detected internally and triggers the fault condition.
- Integrated current shunt configuration: a current shunt is included on the negative bus of the inverter. Over-current is detected internally and triggers the fault condition.

Part Number	Integrated High Voltage ICs	Current Rating @T _C =25°C	Current Rating @T _C =100°C	Over-Current Trip (typ.)	V (I _{trip})	Package
IRAMS06UP60A	IR21365	6A	3A	User Defined	4.30V	SIP1
IRAMS06UP60B	IR21363	6A	3A	9.8A	0.49V	SIP1
IRAMS10UP60A	IR21365	10A	5A	User Defined	4.30V	SIP1
IRAMS10UP60B	IR21363	10A	5A	14.8A	0.49V	SIP1
IRAM16UP60A	IR21365	16A	8A	User Defined	4.30V	SIP2
IRAM16UP60B	IR21363	16A	8A	27.1A	0.49V	SIP2
IRAM20UP60A	IR21365	20A	10A	User Defined	4.30V	SIP2
IRAMY20UP60B	IR21363	20A	11.5A	28.8A	0.49V	SIP3

Intelligent Power Modules - MiniSIP

Part Number	Package	Circuit	V _{CES}	I ₀ @ 25°C	I ₀ @ 100°C	Switching Frequency	R _{DS(on)}
IR3101	9-lead SIP	Half-Bridge FredFET and Gate Driver IC	500V	2A	1.3A	20	1.00hm
IR3101	9-lead SIP	Half-Bridge FredFET and Gate Driver IC	500V	0.7A	-	30	2.50hm

Automotive Intelligent Power Switch Product Families

The IR Advantage

- Most rugged, efficient and compact switches for the harshest environments.
- Provides charge pump and full switch protection with no additional circuitry.
- Up to 30% smaller PCB area than a discrete charge pump circuit.
- More than 1000 times longer life than electro-mechanical relays due to self protection and absence of wear and tear.
- Up to 20% lower on-resistance than relays reduces heat dissipation and heat sinks.

Features at a Glance

- 40V MOSFET with embedded protection and charge pump in a single package.
- 75V capable technology for 24V battery truck and industrial applications.
- As low as 7m0hms RDS(on) in the D²Pak / TO-220 footprint with current sense feedback.
- Integrated low EMI charge pump allows direct logic input.
- Open-load detection (HSS).
- Diagnostic feedback via the input pin on low side devices.

Protection Features

- Over-current protection:
- Shutdown
- Current limiting
- Over-temperature protection
- ESD protection
- Active clamp for inductive loads.

Applications

Ideal replacement for electro-mechanical relays

Automotive

- Transmission Controls
- Junction Boxes
- Electronic Stability Controls
- Anti-lock Brakes, Traction Controls
- Diesel and Gas Direct Injection
- Pump Motors, Radiator Fans
- Head Diesel Glow Plugs
- Lamps

Industrial Automation

- Programmable Logic Controllers (PLC)
- Distributed and Closed-Loop Control Systems
- DC Loads (12VDC and 24VDC)
Valves; Solenoids; Heaters

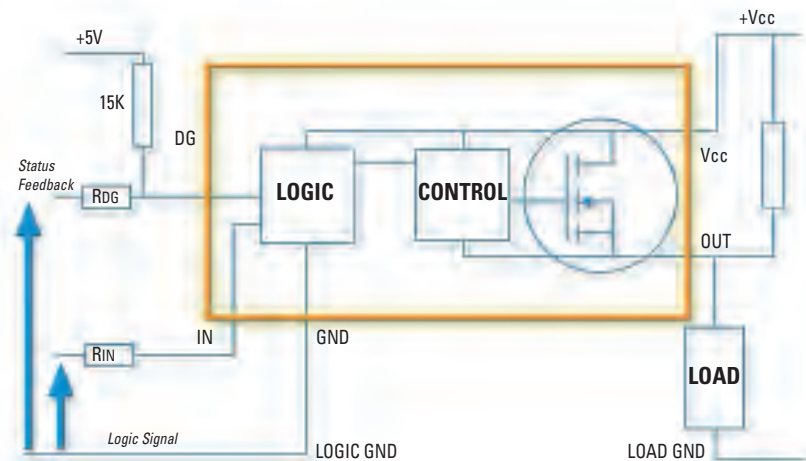

Ultra-Low R_{DS(on)} Self-Protected Intelligent Power Switches

Intelligent Power Switches (IPS) from International Rectifier integrate a low R_{DS(on)} output HEXFET[®] power MOSFET into a single package with protection and control circuits, making them the most rugged, efficient and compact devices available for automotive loads in harsh environments. All devices are qualified to AEC Q100 Qualification standard and devices with "PbF" suffix are RoHs compliant according to the European Union RoHs Directive.

Built-in protection features, like over-temperature, over-current and active inductive energy clamp protect against short circuits, stalled motors and excessive ambient temperature. Designed to safely handle ordinary overload conditions as well as several extraordinary conditions, including loss of ground, load dump and reverse battery, IPS devices eliminate switch failures with the best efficiency and no addition in part count. Over-design for low occurrence fault situations are minimized. The embedded charge pump makes the interface to the micro-controller very simple with full logic-level compatibility.

The double level shifter circuitry that drives the MOSFET in the High-Side Switch (HSS) family provides immunity from large offsets between the logic ground and the load ground and short switching times. Internal slew rate control for turn-on/off and the use of a low noise charge pump means lower EMI, with ground noise generation of less than 10mA.

Product Families **Automotive Intelligent Power Switch**

P/N	Configuration	Output	R _{DS(ON)} (mΩ)	Over current protection	Over temp protection (Shutdown)	V clamp	Package	
IPS1011PbF	Low side	1	13	85A Shut down	165°C	39V	TO-220	
IPS1011RPbF		1	13	85A Shut down	165°C	39V	D-Pak	
IPS1011SPbF		1	13	85A Shut down	165°C	39V	D ² Pak	
IPS1021PbF		1	25	35A Shut down	165°C	39V	TO-220	
IPS1021RPbF		1	25	35A Shut down	165°C	39V	D-Pak	
IPS1021SPbF		1	25	35A Shut down	165°C	39V	D ² Pak	
IPS1031PbF		1	50	18A Shut down	165°C	39V	TO-220	
IPS1031RPbF		1	50	18A Shut down	165°C	39V	D-Pak	
IPS1031SPbF		1	50	18A Shut down	165°C	39V	D ² Pak	
IPS1041LPBF		1	100	6A Shut down	165°C	39V	SOT-223	
IPS1041RPBF		1	100	6A Shut down	165°C	39V	D-Pak	
IPS1042GPBF		2	100	6A Shut down	165°C	39V	SO-8	
IPS1051LPBF		1	200	3A Shut down	165°C	39V	SOT-223	
IPS1052GPBF		2	200	3A Shut down	165°C	39V	SO-8	
IPS2041LPBF		1	130	5A Shut down	165°C	70V	D-Pak	
IPS2041RPBF		1	130	5A Shut down	165°C	70V	SOT-223	
IPS6011PbF		High side	1	14	60A limit	165°C	39V	TO-220 5P
IPS6011RPbF			1	14	60A limit	165°C	39V	D-Pak 5P
IPS6011SPbF			1	14	60A limit	165°C	39V	D ² Pak 5P
IPS6021PbF			1	30	32A limit	165°C	39V	TO-220 5P
IPS6021RPbF	1		30	32A limit	165°C	39V	D-Pak 5P	
IPS6021SPbF	1		30	32A limit	165°C	39V	D ² Pak 5P	
IPS6031PbF	1		55	16A limit	165°C	39V	TO-220 5P	
IPS6031RPbF	1		55	16A limit	165°C	39V	D-Pak 5P	
IPS6031SPbF	1		55	16A limit	165°C	39V	D ² Pak 5P	
IPS6041GPBF	1		130	7A limit	165°C	39V	SO-8	
IPS6041RPBF	1		130	7A limit	165°C	39V	D-Pak 5P	
IPS6041PBF	1		130	7A limit	165°C	39V	TO-220 5P	
IPS6041SPBF	1		130	7A limit	165°C	39V	D ² Pak 5P	
IPS7091GPBF	1		120	5A limit	165°C	70V	SO-8	
IPS7071GPBF	1		120	5A limit	165°C	70V	SO-8	
IPS7091PBF	1		120	5A limit	165°C	70V	TO-220 5P	
IPS7091SPBF	1		120	5A limit	165°C	70V	D ² Pak 5P	
IPS7081RPBF	1		70	6A limit	165°C	70V	D-Pak 5P	
IPS7081PBF	1		70	6A limit	165°C	70V	TO-220 5P	
IPS7081SPBF	1		70	6A limit	165°C	70V	D ² Pak 5P	
IR3316S	High Side with Current Sense	1	7	10 - 90A Programmable shut down	165°C	40V	D ² Pak 5P	
IR3313S		1	7	10 - 90A Programmable shut down	165°C	40V	D ² Pak 5P	
IR3313PBF		1	7	10 - 90A Programmable shut down	165°C	40V	TO-220 5P	
IR3314SPBF		1	12	6 - 58A Programmable shut down	165°C	40V	D ² Pak 5P	
IR3314PBF		1	12	6 - 58A Programmable shut down	165°C	40V	TO-220 5P	
IR3315SPBF		1	20	3 - 30A Programmable shut down	165°C	40V	D ² Pak 5P	
IR3315PBF		1	20	3 - 30A Programmable shut down	165°C	40V	TO-220 5P	

Automotive Intelligent Power Switch Product Families

Features at a Glance

- Integrated charge pump and gate drive for high-side applications
- Load current feedback
- Programmable over-current shutdown
- Over-temperature shutdown
- Active clamp
- Reverse battery protection
- Reverse current capability
- ESD protection

The IR Advantage

- +/- 5% current sense feedback accuracy
- 100 kHz current feedback bandwidth
- Very low $R_{DS(ON)}$ fully protected high-side switch
- Programmable current shutdown
- Simplifies circuits and increases reliability

Applications

- Automotive 14V applications
- Body modules
- Intelligent Glow-plug
- Auxiliary PTC heater
- Engine cooling fan
- Interior fan control

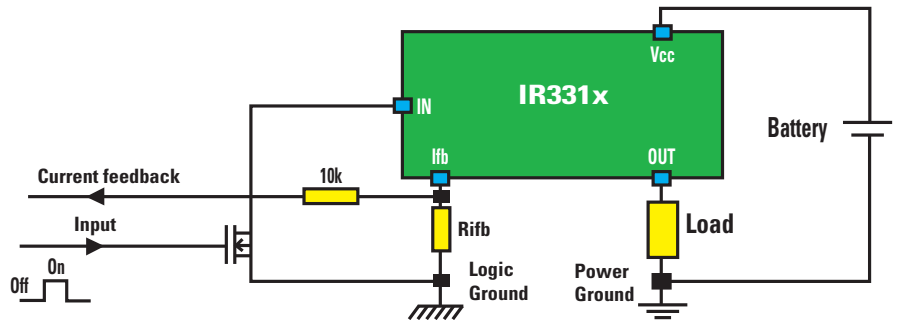

The IR331x family are highly efficient high side power switches that feature integrated programmable over-current protection, over-temperature protection, and active overvoltage clamping. In addition, the IR331x family provides a current feedback output with +/- 5% accuracy over the full operating temperature range (@max. load current) compared to about +/- 20% for competitive devices. This accuracy combined with integrated programmable over-current shutdown enables the IR331x switches to protect not only itself but also the load by optimizing the shutdown threshold.

The current feedback feature allows precise current monitoring and control for a very cost effective solution in many applications. With +/- 5% accuracy and 100 kHz bandwidth, the current feedback signal may be used by a standard PWM control IC, ASIC, or microcontroller to implement high-performance functionality from wide bandwidth closed-loop current control of a motor load to basic load fault detection. Implementing current sense functions with the IR331x family eliminates the power loss of a shunt resistor or cost of a Hall sensor.

The IR331x devices are specifically designed for automotive 14V applications where a protection is required in order to prevent the IC and the application from damage in case of short circuits on the line, or by overload. The integrated over-temperature protection and programmable over-current shutdown features save additional fuses and wiring harness, improving the system reliability. Additional integrated features like ESD, reverse battery and active clamp guarantee protection even under harsh automotive operating conditions.

Product Families **Automotive Intelligent Power Switch**

IR331x Block Diagram

The input signal is referenced to V_{CC} . When the input voltage $V_{CC} - V_{IN}$ exceeds the specified threshold, the output power MOSFET is turned on. When the $V_{CC} - V_{IN}$ is lower than the specified V_{IL} threshold, the output MOSFET is turned off. Any fault will disable the output MOSFET until V_{IN} is cycled off, resetting the fault latch. A current proportional to the power MOSFET current is sourced to the IFB pin and allows easy measurement of the output current. Over current shutdown threshold occurs at $V_{IFB} - V_{IN} > 4V$. Programming the over-current threshold is achieved by choosing R_{IFB} .

Functional Block Diagram

All values are typical

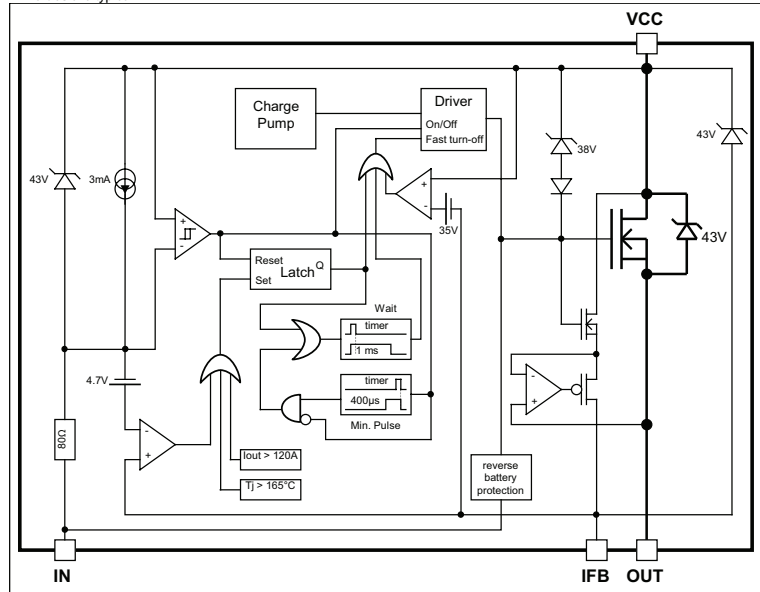

IR331x Operation

The bottom traces show the load current and the diagnostic current (vertical scale is adjusted to match.)

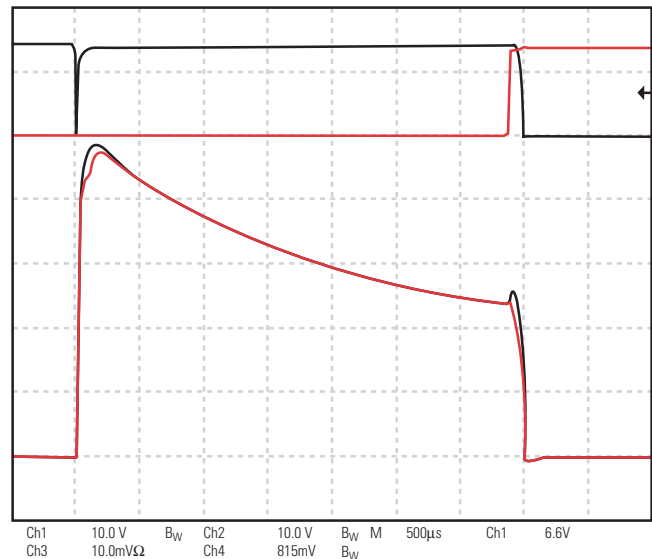

Specifications

Part	Configuration	Output	$R_{ds(ON)}$ (mOhm)	Over current protection	Over Temp Protection Shut Down	V_{clamp}	Package
IR3316S	High Side with Current Sense	1	7	10-90A (Programmable shut down)	145°C	40V	D ² Pak 5P
IR3313S		1	7	10-90A (Programmable shut down)	145°C	40V	D ² Pak 5P
IR3313PbF		1	7	10-90A (Programmable shut down)	145°C	40V	TO-220 5P
IR3314SPbF		1	12	6-58A (Programmable shut down)	145°C	40V	D ² Pak 5P
IR3314PbF		1	12	6-58A (Programmable shut down)	145°C	40V	TO-220 5P
IR3315SPbF		1	20	3-30A (Programmable shut down)	145°C	40V	D ² Pak 5P
IR3315PbF		1	20	3-30A (Programmable shut down)	145°C	40V	TO-220 5P

Micro Electronic Relays Product Families

The IR Advantage

(compared against EMR)

- Miniature size
- No contact bounce
- Long operational life
- High input sensitivity
- High reliability
- Insensitivity to stray electromagnetic fields
- Insensitivity to shock and vibration
- Stable contact resistance over life

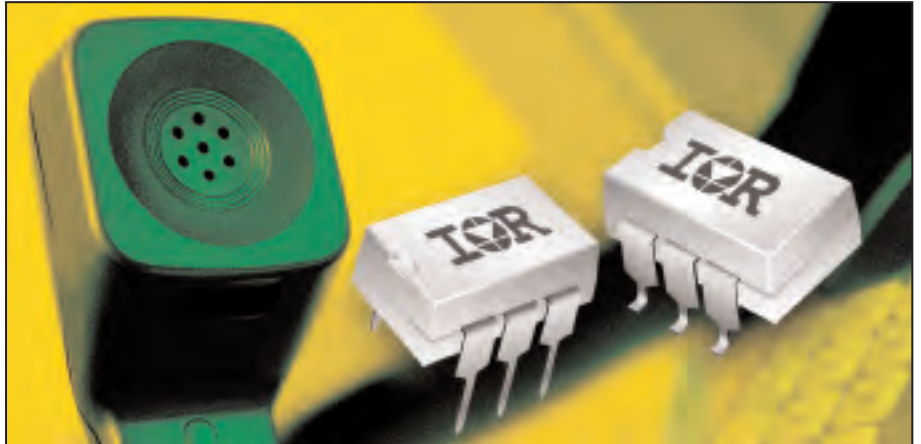

International Rectifier Microelectronic Relays

International Rectifier microelectronic relays consist of HEXFET® power MOSFET and IGBT output photovoltaic relays, as well as a line of photovoltaic isolators. The operating parameters of photovoltaic relays are ideal for switching low-level signal loads in instrumentation and data acquisition to medium power loads in industrial controls and process automation, i.e. from microvolts and microamps to 400 volts (AC peak or DC) and up to 6.0 amps of load current at a contact resistance as low as 15 milliohms.

The IR line of specialized telecom relays offers numerous contact configurations, package styles, and functional integration with ringer detection in addition to single-pole contacts and small-profile ThinPak packages compatible with applications in Type II PCMCIA cards. Photovoltaic isolators offer single- and dual-channel, optically isolated outputs that can be used for directly driving the gates of discrete power MOSFETs and/or IGBTs, giving designers the flexibility of creating their own, custom-made solid-state relays capable of controlling loads well over 1,000 volts and 100 amps.

DC Only Load

Name	Package	Circuit	Operating Voltage (+) (V)	Resistance DC (Ohms)	Current DC (mA)	Control Current (mA)	Off-State Resistance (Ohms)	Dielectric Strength (V)	Response Time On (usec)	Response Time Off (usec)	Thermal Offset (V)	PbF Option Available
PVD1352N	mod. 8-pin DIP	1 Form A	100	1.5	550	5	1E+08	4000	150	125	0.2	✓
PVD1352NS	mod. 8-pin SMT	1 Form A	100	1.5	550	5	1E+08	4000	150	125	0.2	✓
PVD1354N	mod. 8-pin DIP	1 Form A	100	1.5	550	5	1E+10	4000	150	125	0.2	✓
PVD1354NS	mod. 8-pin SMT	1 Form A	100	1.5	550	5	1E+10	4000	150	125	0.2	✓
PVD2352N	mod. 8-pin DIP	1 Form A	200	6.0	240	5	1E+08	4000	100	110	0.2	✓
PVD2352NS	mod. 8-pin SMT	1 Form A	200	6	240	5	1E+08	4000	100	110	0.2	✓
PVD3354N	mod. 8-pin DIP	1 Form A	300	6.0	240	5	1E+10	4000	100	110	0.2	✓
PVD3354NS	mod. 8-pin SMT	1 Form A	300	6	240	5	1E+10	4000	100	110	0.2	✓
PVDZ172N	mod. 8-pin DIP	1 Form A	60	0.25	1500	10	1E+08	4000	2000	500		✓
PVDZ172NS	mod. 8-pin SMT	1 Form A	60	0.25	1500	10	1E+08	4000	2000	500		✓

Product Families **Micro Electronic Relays**

MER: Photovoltaic Relay **AC/DC Load**

Name	Package	Circuit	Operating Voltage (+) (V)	Operating Voltage (-) (V)	On-State Resistance AC (Ohms)	On-State Resistance DC (Ohms)	Load Current AC (mA)	Load Current DC (mA)	Nominal Control Current (mA)	Off-State Resistance (Ohms)	Dielectric Strength (V)	Response Time On (usec)	Response Time Off (usec)	Thermal Offset (V)	PbF Option Available
PVA1352N	mod. 8-pin DIP	1 Form A	100	100	5		375	375	5	1E+08	4000	150	125	0.2	✓
PVA1352NS	mod. 8-pin SMT	1 Form A	100	100	5		375	375	5	1E+08	4000	150	125	0.2	✓
PVA1354N	mod. 8-pin DIP	1 Form A	100	100	5		375	375	5	1E+10	4000	150	125	0.2	✓
PVA1354NS	mod. 8-pin SMT	1 Form A	100	100	5		375	375	5	1E+10	4000	150	125	0.2	✓
PVA2352N	mod. 8-pin DIP	1 Form A	200	200	24		150	150	5	1E+08	4000	100	110	0.2	✓
PVA2352NS	mod. 8-pin SMT	1 Form A	200	200	24		150	150	5	1E+08	4000	100	110	0.2	✓
PVA3054N	mod. 8-pin DIP	1 Form A	300	300	160		50	50	5	1E+10	4000	60	100	0.2	✓
PVA3054NS	mod. 8-pin SMT	1 Form A	300	300	160		50	50	5	1E+10	4000	60	100	0.2	✓
PVA3055N	mod. 8-pin DIP	1 Form A	300	300	160		50	50	5	1E+11	4000	60	100	0.2	✓
PVA3055NS	mod. 8-pin SMT	1 Form A	300	300	160		50	50	5	1E+11	4000	60	100	0.2	✓
PVA3324N	mod. 8-pin DIP	1 Form A	300	300	24		150	150	2	1E+10	4000	100	110	0.2	✓
PVA3324NS	mod. 8-pin SMT	1 Form A	300	300	24		150	150	2	1E+10	4000	100	110	0.2	✓
PVA3354N	mod. 8-pin DIP	1 Form A	300	300	24		150	150	5	1E+10	4000	100	110	0.2	✓
PVA3354NS	mod. 8-pin SMT	1 Form A	300	300	24		150	150	5	1E+10	4000	100	110	0.2	✓
PVAZ172N	mod. 8-pin DIP	1 Form A	60	60	0.5		1000	1000	10	1E+08	4000	2000	500		✓
PVAZ172NS	mod. 8-pin SMT	1 Form A	60	60	0.5		1000	1000	10	1E+08	4000	2000	500		✓
PVG612	6-pin DIP	1 Form A	60	60	0.5	0.15	1000	2000	5	1E+08	4000	2000	500		✓
PVG612A	6-pin DIP	1 Form A	60	60	0.1	0.035	2000	4000	5	.6E+08	4000	3500	500		✓
PVG612AS	6-pin SMT	1 Form A	60	60	0.1	0.035	2000	4000	5	.6E+08	4000	3500	500		✓
PVG612S	6-pin SMT	1 Form A	60	60	0.5	0.15	1000	2000	5	1E+08	4000	2000	500		✓
Name	Package	Circuit	Operating Voltage (+) (V)	Operating Voltage (-) (V)	On-State Resistance AC (Ohms)	On-State Resistance DC (Ohms)	Load Current AC (mA)	Load Current DC (mA)	Nominal Control Current (mA)	Off-State Resistance (Ohms)	Dielectric Strength (V)	Response Time On (usec)	Response Time Off (usec)	Thermal Offset (V)	PbF Option Available
PVG613	6-pin DIP	1 Form A	60	60	0.5	0.25	1	2	5	4.8E+09	4000	2000	500	NA	✓
PVG613S	6-pin SMT	1 Form A	60	60	0.5	0.25	1	2	5	4.8E+09	4000	2000	500	NA	✓
PVN012	6-pin DIP	1 Form A	20	20	0.1	0.04	2500	4500	3	.16E+08	4000	5000	500		✓
PVN012APBF	6-pin DIP	1 Form A	20	20	0.05	0.015	4000	6000	5		4000	3000	500		✓
PVN012S	6-pin SMT	1 Form A	20	20	0.1	0.04	2500	4500	3	.16E+08	4000	5000	500		✓
PVN013	6-pin DIP	1 Form A	20	20	0.1	0.065	2.5	4.5	3	1.6E+09	4000	5000	500	NA	✓
PVN013S	6-pin SMT	1 Form A	20	20	0.1	0.065	2.5	4.5	3	1.6E+09	4000	5000	500	NA	✓
PV0402AP	Thin-Pak	1 Form A	400	400	22	22	150	150	5	4E+08	3750	1000	500		—
PV0402P	Thin-Pak	1 Form A	400	400	35	35	120	120	3	4E+08	3750	2000	500		—
PVR1300N	16-pin DIP	1 Form A	100	100	5	3	360	420	2.0	10^8	1500	150	125	0.2	✓
PVR1301N	16-pin DIP	1 Form A	100	100	5	3	360	420	2.0	10^10	1500	150	125	0.2	✓
PVR2300N	16-pin DIP	2 Form A	200	200	24	6	310	310	5	1E+08	1500	150	125	0.2	✓
PVR3300N	16-pin DIP	2 Form A	300	300	24	6	310	310	5	1E+08	1500	150	125	0.2	✓
PVR3301N	16-pin DIP	2 Form A	300	300	24	6	310	310	5	1E+10	1500	150	125	0.2	✓
PVT212	6-pin DIP	1 Form A	150	150	0.75	0.25	550	825	5	1.5E+08	4000	3000	500		✓
PVT212S	6-pin SMT	1 Form A	150	150	0.75	0.25	550	825	5	1.5E+08	4000	3000	500		✓
PVT312	6-pin DIP	1 Form A	250	250	10	3	190	320	2	2.5E+08	4000	3000	500		✓
PVT312L	6-pin DIP	1 Form A	250	250	15	4.25	170	300	2	2.5E+08	4000	3000	500		✓
PVT312LS	6-pin SMT	1 Form A	250	250	15	4.25	170	300	2	2.5E+08	4000	3000	500		✓
PVT312S	6-pin SMT	1 Form A	250	250	15	4.25	190	320	2	2.5E+08	4000	3000	500		✓

Micro Electronic Relays Product Families

MER: Photovoltaic Relay AC/DC Load

Name	Package	Circuit	Operating Voltage (+) (V)	Operating Voltage (-) (V)	On-State Resistance AC (Ohms)	On-State Resistance DC (Ohms)	Load Current AC (mA)	Load Current DC (mA)	Nominal Control Current (mA)	Off-State Resistance (Ohms)	Dielectric Strength (V)	Response Time On (usec)	Response Time Off (usec)	Thermal Offset (V)	PbF Option Available
PVT322	8-pin DIP	2 Form A	250	250	10	10	170	170	2	2.5E+08	4000	3000	500		✓
PVT322A	8-pin DIP	2 Form A	250	250	8	8	170	170	2	2.5E+08	4000	3000	500		✓
PVT322AS	8-pin SMT	2 Form A	250	250	8	8	170	170	2	2.5E+08	4000	3000	500		✓
PVT322S	8-pin SMT	2 Form A	250	250	10	10	170	170	2	2E+08	4000	3000	500		✓
PVT412	6-pin DIP	1 Form A	400	400	27	7	140	210	3	4E+08	4000	2000	500	0.5	✓
PVT412A	6-pin DIP	1 Form A	400	400	6	2	240	360	3	4E+08	4000	3000	500	0.5	✓
PVT412AS	6-pin SMT	1 Form A	400	400	6	2	240	360	3	4E+08	4000	3000	500	0.5	✓
PVT412L	6-pin DIP	1 Form A	400	400	35	9	120	200	3	4E+08	4000	2000	500	0.5	✓
PVT412LS	6-pin SMT	1 Form A	400	400	35	9	120	200	3	4E+08	4000	2000	500	0.5	✓
PVT412S	6-pin SMT	1 Form A	400	400	27	7	140	210	3	4E+08	4000	2000	500		✓
PVT422	8-pin DIP	2 Form A	400	400	35	35	120	120	2	3.2E+08	4000	2000	2000		✓
PVT422P	Thin-Pak	2 Form A	400	400	35	35	120	120	2	3.2E+08	3750	2000	2000		—
PVT422S	8-pin SMT	2 Form A	400	400	35	35	120	230	2	3.2E+08	4000	2000	2000		✓
PVU414	6-pin DIP	1 Form A	400	400	27	7	140	210	3	1E+10	4000	500	200	0.2	✓
PVU414S	6-pin SMT	1 Form A	400	400	27	7	140	210	3	1E+10	4000	500	200	0.2	✓
PVX6012	14-pin DIP	1 Form A	400	400			1	1	5	.4E+08	3750	7000	1000		✓
PVY116	4 Lead SOP	1 Form A	40	40	4.4	4.4	250	250	2.0	3.2E+10	1500	500	500		✓
PVY117	4 Lead SOP	1 Form A	40	40	0.95	0.95	470	470	2	4E+10	1500	200	100		✓

MER: Photovoltaic Isolator

Name	Package	Circuit	Number of Outputs	Output Voltage (V)	Short Circuit Current	Nominal Control Current (mA)	PbF Option Available
PVI1050N	8-pin DIP	2 Form A	2	5	5	10	✓
PVI1050NS	8-pin SMT	2 Form A	2	5	5	10	✓
PVI5013R	8-pin DIP	2 Form A	2	5	1	10	✓
PVI5013RS	8-pin SMT	2 Form A	2	3	1	5	✓
PVI5033R	8-pin DIP	2 Form A	2	5	5	5	✓
PVI5033RS	8-pin SMT	2 Form A	2	5	5	5	✓
PVI5050N	mod. 8-pin DIP	1 Form A	1	5	5	10	✓
PVI5050NS	mod. 8-pin SMT	1 Form A	1	5	5	10	✓
PVI5080N	mod. 8-pin DIP	1 Form A	1	5	8	10	✓
PVI5080NS	mod. 8-pin SMT	1 Form A	1	5	8	10	✓

Product Families Automotive Trench MOSFETS

Electron Flow

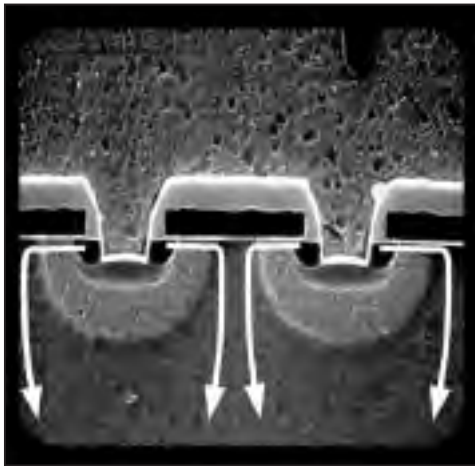

Planar

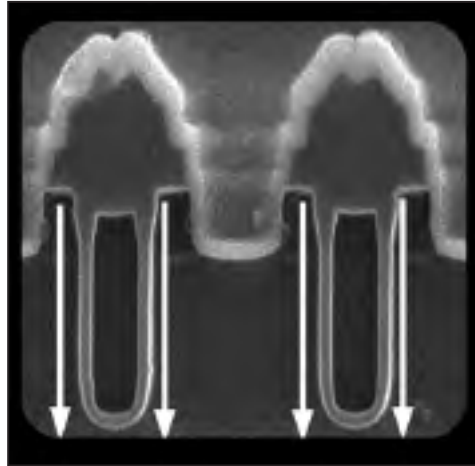

Trench

International Rectifier automotive Trench HEXFET® Power MOSFETs feature improved efficiency, switching performance and ruggedness compared to competitive Trench technology. IR Trench process has been uniquely optimized to extend the benefits of Trench technology to the harsh automotive environment without sacrificing the avalanche ruggedness that automotive system designers have come to expect from IR's planar MOSFETs.

With high power automotive applications in mind, IR Trench technology has been optimized for low on-resistance and offers 15% lower $R_{DS(on)}$ per unit area than best competitive devices and 45% lower than best planar technology.

Features at a Glance

- Positive (V_{ce}) on Temperature Coefficient provides excellent current sharing in parallel operation
- 70um technology – this info is included in the Warp 2 section so you may want to include it here for symmetry
- 5us Short Circuit rating
- Square RBSOA
- May be able to justify “Industry Std Switching Losses” since we are better than Infineon in this category (ref DR2 Package)

The IR Advantage

Compared to the best competitive Trench devices in the market:

- Lowest $R_{DS(on)}$ per unit area at elevated temperature
- Excellent avalanche capability
- Low gate charge

Applications

High power applications including:

- Integrated Starter Alternator
- Synchronous Rectifier Alternators
- Electrical Power Steering
- Brush and brushless DC motor control

Part Number	Package	Circuit	Ic @ 25C	Ic @100C	(Vce)on @ 25C
IRGP4068D	TO-247	Co-Pack	96.0A	48.0A	2.14V
IRGP4062D	TO-247	Co-Pack	48.0A	24.0A	1.95V
IRGP4061D	TO-247	Co-Pack	36.0A	18.0A	1.95V
IRGP4056D	TO-247	Co-Pack	24.0A	12.0A	1.85V
IRGP4060D	TO-247	Co-Pack	16.0A	8.0A	1.85V
IRGB4062D	TO-220	Co-Pack	48.0A	24.0A	1.95V
IRGB4061D	TO-220	Co-Pack	36.0A	18.0A	1.95V
IRGB4056D	TO-220	Co-Pack	24.0A	12.0A	1.85V
IRGB4064D	TO-220	Co-Pack	20.0A	10.0A	1.85V
IRGB4060D	TO-220	Co-Pack	16.0A	8.0A	2.00V
IRGB4059D	TO-220	Co-Pack	8.0A	4.0A	2.05V

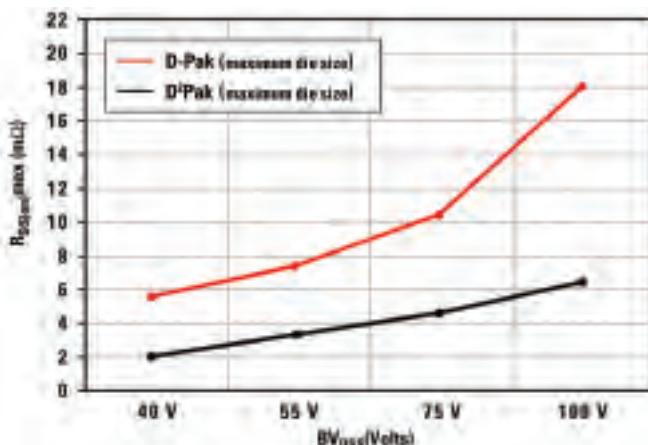

Automotive Trench MOSFETS Product Families

Trench HEXFET® Power MOSFETs

Part #	Package ⁽⁴⁾	V _{DS} (V)	R _{DS(on)} (mW)	I _{D, max} (A)	R _{th} (C/W) _{max}	Typ R _{dson} Temp Coeff.
IRF2903Z	D ² Pak	30	2.6	75 ⁽¹⁾	0.51	Std
IRF2804S	D ² Pak	40	2.0	75	0.45	Std
IRF2804S-7P	D ² Pak-7P	40	1.6	160 ⁽¹⁾	0.50	Std
IRF1404ZS	D ² Pak	40	3.7	75	0.65	Std
IRL1404ZS	DPak	40	5.9	75	0.65	Logic
IRF4104S	D ² Pak	40	5.5	75	1.05	Std
IRFR4104	DPak	40	5.5	42 ⁽¹⁾	1.05	Std
IRFR3504Z	DPak	40	9.0	42	1.66	Std
IRF1405ZS-7P	D ² Pak-7P	55	4.9	120	0.65	Std
IRF1405ZS	D ² Pak	55	4.9	75	0.65	Std
IRF3805ZS-7P	D ² Pak-7P	55	2.6	160	0.5	Std
IRF3805ZS	D ² Pak	55	3.3	75	0.45	Std
IRF3205ZS	D ² Pak	55	6.5	75	0.67	Std
IRF1010ZS	D ² Pak	55	7.5	75	1.11	Std
IRFR1010Z	DPak	55	8.5	42	1.11	Std
IRFZ48ZS	D ² Pak	55	11.0	61	1.64	Std
IRL3705ZS	D ² Pak	55	12.0	75	1.18	Logic
IRLR3705Z	DPak	55	13.0	42	1.18	Logic
IRFZ46ZS	D ² Pak	55	13.6	51	1.84	Std
IRFR2905Z	DPak	55	14.5	42	1.38	Std
IRFZ44ZS	D ² Pak	55	14.0	51	1.87	Std
IRLR2905Z	DPak	55	22.5	42	1.9	Logic
IRLZ44ZS	D ² Pak	55	22.5	60	1.87	Logic
IRFR4105Z	DPak	55	24.5	30 ⁽¹⁾	3.12	Std
IRFL024Z	SOT-223	55	57.5	5.1	45	Std
IRLL024Z	SOT-223	55	100	16	4.28	Logic
IRLR024Z	DPak	55	100	16	4.28	Logic
IRFR48Z	DPak	55	12	30	1.64	Std
IRFR46Z	DPak	55	14.5	30	1.84	Std
IRLR3915	DPak ⁽³⁾	55	14	30	1.3	Std
IRF3305	TO-220 ^(2,3)	55	8	75	0.45	Std
IRF1010EZS	D ² Pak	60	8.5	75	1.11	Std
IRFZ44VZS	D ² Pak	60	12.0	57	1.64	Std
IRF2907ZS	D ² Pak	75	4.5	75	0.45	Std
IRF2807ZS	D ² Pak	75	9.4	75	0.9	Std
IRFR2307Z	DPak	75	16	42	1.5	Std
IRFR2607Z	DPak	75	22	40	1.9	Std
IRFS3207	D ² Pak	75	4.5	75	0.5	Std
IRF3307	D ² Pak	75	6.3	75	0.6	Std
IRF3507	D ² Pak	75	8.8	75	0.8	Std
IRFR3710Z	DPak	100	18.0	42	1.05	Std
IRF540ZS	D ² Pak	100	26.5	36	1.64	Std
IRFR120Z	DPak	100	190	8.7	4.28	Std
IRFR540Z	DPak	100	27	30	1.64	Std
IRFS4610	D ² Pak	100	14	70	0.8	Std
IRFS4410	D ² Pak	100	10	75	0.6	Std
IRFS4310	D ² Pak	100	7	75	0.5	Std

1) Package limit on 75A D²Pak, 160A 7-Pin D²Pak, 42A DPak an 30A DPak

2) Planar Technology

3) Designed for applications that require linear gate drive

4) Check availability in other packages such as TO-220, TO-262, I-Pak at auto.irf.com



The International Rectifier DirectFET power package

The International Rectifier DirectFET power package is a breakthrough surface-mount power MOSFET packaging technology designed for efficient topside cooling in a SO-8 footprint. In combination with improved bottom-side cooling, the new package can be cooled on both sides to cut part count by up to 60%, and board space by as much as 50% compared to devices in standard or enhanced SO-8 packages. This effectively doubles current density (A/in^2) at a lower total system cost. The DirectFET MOSFET family offerings match 20V and 30V synchronous buck converter MOSFET chipsets, followed by the addition at 30V targeted for high frequency operation. The DirectFET MOSFET family is also available in three different can sizes giving maximum flexibility for all your design needs.



The DirectFET Discovery Center is intended for customers that are looking for a deeper understanding of DirectFET device innovative features as well as examples of applications in which it can be used to boost circuit performances both from electrical and thermal point of view features. The Discovery Center is organized in the following sections:

- DirectFET MOSFET Overview features a complete and deep description of the package's electrical, mechanical and thermal characteristics.
- Applications features a portfolio of reference and feasible designs using DirectFET MOSFETs.
- Engineering features a production cycle related description of the DirectFET MOSFET's unique properties.
- FAQs features detailed, quick and engineering oriented answers to frequently asked questions.

For more info visit:
www.irf.com/product-info/directfet/dfdsccovery/

Features at a Glance

- RoHs compliant containing no lead or bromide

Not all DirectFET MOSFETs are qualified for use with lead-free solder; see PbF Qualification pages to determine part status.

- 1.4°C/W junction to case thermal resistance ($R_{th(J-C)}$) enables highly effective top-side cooling
- Less than 1°C/W $R_{th(junction-pcb)}$ in same footprint as SO-8
- Over 90% lower die-free package resistance (DFPR) than SO-8
- 0.7mm profile compared to 1.75mm for SO-8
- Direct chip attach with no wire bonding or lead-frame
- Lower package inductance for higher frequencies
- Compatible with high volume manufacturing equipment and processes

The IR Advantage

- Increases current density by a factor of two
- Cuts MOSFET part count by 60%
- Reduces PCB space by 50%
- Up to 50°C lower operating temperature increases reliability
- Lower total system cost

Applications

- VRM modules for Servers (sync buck)
- Workstations and mainframes (sync rectification, ORing)
- High-performance notebooks (sync buck)
- Advanced telecom and datacom systems (bus converter)
- Radio controlled toys (motor control)
- Battery operated tools (motor control)
- Class D audio

DirectFET[®] MOSFETS Product Families

DirectFET Low Voltage MOSFETS

Part Number	BVDSS Max. (V)	Application	R _{DS(ON)}		V _{GS} Max. (V)	I _D @25 (A)	Q _G Typ. (nC)	Q _{GD} Typ. (nC)	Q _{SW} Typ. (nC)	AN-1035 Layout Code	1" Sq Rthj-a °C/W	Rthj-c °C/W
			@ 10V Max. (m _Ω)	@ 4.5V Max. (m _Ω)								
IRF6608	30	Ctrl FET	9.0	11.0	±12	55	16	5.3	6.7	ST	58	3
IRF6609TRPBF	20	Sync FET	2.0	2.6	±20	150	46	15	20	MT	45	1.4
IRF6619TRPBF		Sync FET	2.2	3.0	±20	150	38	13	17	MX	45	1.4
IRF6620TRPBF		Sync FET	2.7	3.6	±20	150	28	8.8	12	MX	45	1.4
IRF6636TRPBF		Sync FET	4.5	6.4	±20	81	18	6.1	8	ST	58	3
IRF6623TRPBF		Ctrl FET	5.7	9.7	±20	55	11	4.0	5.2	ST	58	3
IRF6633TRPBF		Ctrl FET	5.6	9.4	±20	59	11	4.0	5.2	MP	45	1.4
IRF6610TRPBF		Ctrl FET	6.8	10.7	±20	66	11	3.6	4.9	SQ	58	3
IRF6716MTRPBF		Sync FET	1.6	2.4	±20	160	41	14.2	18.4	MX	32	1.8
IRF6629TRPBF	25	Sync FET	2.1	2.7	±20	180	34	11	15	MX	45	1.2
IRF6628TRPBF		Sync FET	2.5	3.3	±20	160	31	12	16	MX	45	1.3
IRF6622TRPBF		Ctrl FET	6.3	8.9	±20	59	11	3.8	5.4	SQ	58	3.7
IRF6635TRPBF		Sync FET	1.8	2.4	±20	180	47	17	29	MX	45	1.4
IRF6678TRPBF	30	Sync FET	2.2	3.0	±20	150	43	15	19	MX	45	1.4
IRF6618TRPBF		Sync FET	2.2	3.4	±20	150	43	15	19	MT	45	1.4
IRF6611TRPBF		Sync FET	2.6	3.4	±20	150	37	12.5	15.8	MX	45	1.4
IRF6638TRPBF		Sync FET	2.9	3.9	±20	140	30	11	14	MX	45	1.4
IRF6612TRPBF		Sync FET	3.3	4.4	±20	136	30	10	13	MX	45	1.4
IRF6626TRPBF		Sync/Ctrl	5.4	7.1	±20	72	19	6.7	8.3	ST	58	3
IRF6631TRPBF		Ctrl FET	7.8	10.8	±20	57	12	4.4	5.5	SQ	58	3
IRF6637TRPBF		Ctrl FET	7.7	10.8	±20	52	11	4.0	5.0	MP	45	1.4
IRF6617TRPBF		Ctrl FET	8.1	10.3	±20	52	11	4.0	5.0	ST	58	3
IRF6621TRPBF		Ctrl FET	9	12.1	±20	55	11.7	4.2	5.2	SQ	58	3
IRF6613TRPBF		Sync Rect	3.4	4.1	±20	150	42	11.5	15.9	MT	45	1.4
IRF6616TRPBF		40	Sync Rect	5.0	6.2	±20	106	29	9.4	12	MX	45
IRF6614TRPBF	Sync Rect		8.3	9.9	±20	55	19	6.0	7.4	ST	58	3

DirectFETKY

IRF6691TRPBF	20	Sync FET	1.8	2.5	±12	180	47	15	19	MT	45	1.4
--------------	----	----------	-----	-----	-----	-----	----	----	----	----	----	-----

DirectFET Mid Voltage MOSFETS

Part Number	BVDSS Max. (V)	Application	R _{DS(ON)}		V _{GS} Max. (V)	I _D @25 (A)	Q _G Typ. (nC)	Q _{GD} Typ. (nC)	Q _{SW} Typ. (nC)	AN-1035 Layout Code	1" Sq Rthj-a °C/W	Rthj-c °C/W
			@ 10.0V Max. (m _Ω)	@ 4.5V Max. (m _Ω)								
IRF6648TRPBF	60	SR / PB	7	-	±20	86	36	14	17.0	MN	45	1.4
IRF6646TRPBF	80	SR / PB	9.5	-	±20	68	36	12	14	MN	45	1.4
IRF6668TRPBF		SR / PB	15	-	±20	55	22	7.8	9.4	MZ	45	1.4
IRF6644TRPBF	100	SR / PB	13	-	±20	60	35.0	11.5	13.1	MN	45	1.4
IRF6662TRPBF		SR / PB	22	-	±20	47	22	6.8	8.0	MZ	45	1.4
IRF6645TRPBF		SR / PB	35	-	±20	25	14	4.8	5.6	SJ	58	3
IRF6655TRPBF		SR / PB	62	-	±20	19	8.7	2.8	3.4	SH	58	3
IRF6643TRPBF	150	SR / PB	52	-	±20	31	34	12	12	MZ	45	1.4
IRF6641TRPBF	200	SR / PB	65	-	±20	25	34	10	11	MZ	45	1.4

Red font = preliminary data

All mid voltage devices have Ti-Cap except for the IRF6644 & IRF6665

Product Families **FETKY™ MOSFETS**

Dual SO-8

Part Number	B _{VDSS} Max. (V)	Fet	Application	R _{DS(ON)}		V _{GS} Max. (V)	I _D @25 (A)	Q _G Typ. (nC)	Q _{GD} Typ. (nC)	Q _{SW} Typ. (nC)
				@ 10V Max. (mΩ)	@ 4.5V Max. (mΩ)					
IRF8915	20	Q1 & Q2	Ctrl & Sync	18.3	27	±20	8.9	4.9	1.7	2.3
IRF8910		Q1 & Q2	Ctrl & Sync	13.4	18.3		10	7.4	2.5	3.3
IRF9910		Q1	Ctrl	13.4	18.3		10	7.4	2.5	3.4
		Q2	Sync	9.3	11.3		12	15	5.4	6.8
IRF7902	30	Q1	Ctrl	22.6	29.7	±20	6.4	4.6	1.8	2.3
IRF7904		Q2	Sync	14.4	18.7		9.7	6.5	2.3	3.1
		Q1	Ctrl	16.2	20.5		7.6	7.5	2.5	3.1
IRF7905*		Q2	Sync	10.8	13.0		11	14	4.8	5.9
		Q1	Ctrl	21.8	29.3		7.8	4.6	1.7	2.3
IRF7907*		Q2	Sync	17.1	21.3		8.9	6.9	2.5	3.3
		Q1	Ctrl	16.4	20.5		9.1	6.7	2.5	3.2
IRF7907*		Q2	Sync	11.8	13.7		11	14	4.9	6.2
	Q1	Ctrl	16.4	20.5	9.1	6.7	2.5	3.2		
IRF7380	80	Q1 & Q2	Ctrl & Sync	73	-	±20	3.6	15	4.5	-

* Different pin-out than IRF7902 & IRF7904. Matches FDS6982S and Si4834BDY pin-out.

D-Pak / I-Pak

Part Number	B _{VDSS} Max. (V)	R _{DS(ON)}		V _{GS} Max. (V)	I _D @25 (A)	Q _G Typ. (nC)	Q _{GD} Typ. (nC)	Q _{SW} Typ. (nC)
		@ 10V Max. (mΩ)	@ 4.5V Max. (mΩ)					
IRL R/U 3717	20	4.0	5.5	±20	120	21	7.2	9.1
IRF R/U3711Z		5.7	7.8		93	18	6.5	8.3
IRF R/U 3704Z		8.4	11.4		60	9.3	2.7	3.8
IRL R/U 3715Z		11	15.5		49	7.2	2.6	3.5
IRL R/U 3714Z		15	25		37	4.7	1.7	2.4
IRLR/U 8713Pbf	25	4.8	6.3	±20	100	17.4	5.8	8.0
IRLR/U 8711Pbf		5.6	7.8		84	13	4.3	6.2
IRLR/U 8715Pbf		9.4	14.8		73	6.1	2.6	3.4
IRL R/U 7843	30	3.3	4.0	±20	161	34	12	15
IRL R/U 7833		4.5	5.5		140	33	13	15
IRL R/U 8113		6.0	7.4		94	22	6.8	8.5
IRF R/U 3709Z		6.5	8.2		86	17	5.7	7.3
IRF R/U 3707Z		9.5	12.5		56	9.6	3.5	4.4
IRL R/U 7821		10	12.5		65	10	2.5	3.7
IRL R/U 7807Z		13.8	18.2		43	7.0	2.7	3.4

FlipFET MOSFETS Product Families

The IR Advantage

- Up to one-third the area and same performance vs. standard SOIC packages
- Ultra low $R_{DS(on)}$ based on IR HEXFET® trench MOSFET technology
- Low profile at <0.8mm
- Virtual elimination of package parasitics devices
- Compatibility with standard SMT techniques
- Fully electrically tested, delivered in tape-and-reel

Applications

- Smart phones
- Mobile phones
- MP3 Players
- Battery packs
- Portable high-density disk drives



IR's new FlipFET™ packages embody true chip scale packaging (CSP) technology, giving rise to a new generation of super-compact power architectures with increased power density. Achieving the world's first 100% silicon-to-footprint ratio for power MOSFETs, in this new package provide the smallest footprint, lowest profile, and lightest weight solution possible. In this new proprietary package, all of the terminals are on a single side of the die, because the die is the package. So stray inductance and other losses associated with device packaging are minimized or eliminated. With this new FlipFET package, footprints are reduced by up to 1/3rd compared to standard lead frame based power silicon.

IRF6100: Load Management

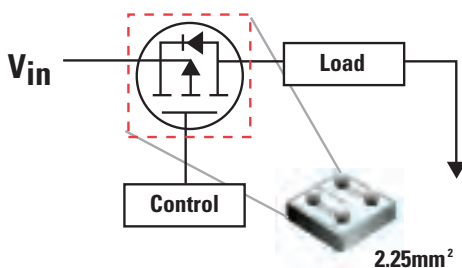

Part Number	B_{VDSS}	V_{GS}	$R_{DS(on)}$	$T_J(max.)$	Configuration
IRF6100	-20V	±12V	65mOhms	150°C	Single P

Product Families **HEXFET®** Power MOSFETS

Low Voltage D2Pak / T0-262 / T0-220

Part Number	B _{VDSS} Max. (V)	R _{DS(ON)}		V _{GS} Max. (V)	I _D @25 (A)	Q _G Typ. (nC)	Q _{GS} Typ. (nC)	Q _{SW} Typ. (nC)
		@ 10V Max. (m _Ω)	@ 4.5V Max. (m _Ω)					
IRF3711Z*	20	6	7.3	±20	92	16	5.3	6.7
IRF3704ZC*		7.9	11.1		67	8.7	2.3	3.4
IRL3715ZC*		11	15.5		50	7	2.3	3.2
IRL3714Z*		16	26		36	4.8	1.7	2.5
IRF1324S-7PPbf	24	1.3		±20	303	178		
IRL7833*	30	3.8	4.5	±20	150	32	13	18
IRL8113*		6	7.1		105	23	8.3	13
IRF3709Z*		6.5	8.2		84	16	5.8	10
IRF3707ZC*		9.5	12.5		59	55	3.4	4.4

* D2Pak = S, T0-262 = L, T0-220 = blank

Mid Voltage D2Pak / T0-262 / T0-220

Part Number	B _{VDSS} Max. (V)	R _{DS(ON)}		V _{GS} Max. (V)	I _D @25 (A)	Q _G Typ. (nC)	Q _{GS} Typ. (nC)	Q _{GD} Typ. (nC)
		@ 10V Max. (m _Ω)	@ 4.5V Max. (m _Ω)					
IRF**3206	60	3.0		±20	210	120	29	35
IRF**3306		4.2	-		160	85	20	26
IRF**3077	75	3.3	-	±20	210	160	37	42
IRF2907ZS-7P		4.5	-		170	180	46	65
IRF**3207		4.5	-		180	180	48	68
IRF**3207Z		4.1	-		170	120	27	33
IRF**3307	100	6.3	-	±20	130	120	35	46
IRF**3307Z		5.8	-		120	79	19	24
IRF**3507		8.8	-		97	88	24	36
IRF**4110		4.5	-		180	150	35	43
IRF**4310	100	7	-	±20	140	170	46	62
IRF**4410		10	-		96	120	31	44
IRF**4610		14	-		73	90	20	36
IRF**4227	200	24	-	±30	65	70	-	23

** T0-220 = B, D2Pak = S, T0-262 = SL, -7P = 7 Pin D2Pak

HEXFET® Power MOSFETS Product Families

S0-8

Part Number	B _{VDSS} Max. (V)	R _{DS(ON)}		V _{GS} Max. (V)	I _D @25 (A)	Q _G Typ. (nC)	Q _{GD} Typ. (nC)	Q _{SW} Typ. (nC)
		@ 10V Max. (mΩ)	@ 4.5V Max. (mΩ)					
IRF3717	20	4.4	5.7	±20	20	22	7.3	9.5
IRF7831	30	3.6	4.4	±12	21	40	11	14
IRF7832Z	30	3.8	4.5	±20	21	29	10	13.0
IRF7832		4.0	4.8		20	34	12	14.9
IRF7834		4.5	5.5		19	29	9.8	12.5
IRF7835		4.5	5.7		19	22	7.2	9.3
IRF7836		5.7	7.1		17	18	5.8	7.3
IRF8113		6.0	7.4		16.6	24	8.5	10.5
IRF7805Z		6.8	8.7		16	18	6.2	7.8
IRF7823		8.7	11.9		13	9	3.2	4.0
IRF7821		9.1	12.5		13.6	9.3	2.9	3.7
IRF7413Z		10	13		13	9.5	3.0	4.0
IRF7807Z		13.8	18.2		11	7.2	2.7	3.4
IRF7842		40	5.0		5.9	±20	18	33
IRF7855	60	9.4	-	±20	12	26	9.6	-
IRF7854	80	13.4	-	±20	10	27	8.7	-
IRF7493		15	-		9.3	35	12	-
IRF7853Pbf	100	18	-	±20	8.4	28	10	-
IRF7495		22	-		7.3	34	11.7	-
IRF7494	150	44	-	±20	5.2	36	13.0	-
IRF7492	200	79	-	±20	3.7	39	15	-

REFERENCE DESIGNS



AC-DC ICs Reference Designs

International Rectifier offers a wide range of reference designs for AC-DC applications. Each reference design kit includes a fully assembled and tested demo board along with applicable datasheets and application notes.

Featured Kits

IRAC1150-D2

One Cycle Control μ PFC Daughter Board

- Featuring IR1150S PFC IC
- Brownout, Over Voltage & Open feedback loop protection
- Universal AC input
- Programmable frequency (50kHz-200kHz)
- Full load start up with no minimum load requirements
- Design a PFC Circuit Online, go to PFC Design Software



IRAC1150-300W

PFC IC for use in continuous conduction mode boost converter applications designed for power factor correction and harmonic current reduction.

- Featuring IR1150S PFC IC
- Universal AC input
- Total Power 300W @ 377V DC
- Frequency 50kHz-300kHz programmable
- Design a PFC Circuit Online, go to PFC Design Software



AC-DC ICs Reference Designs

Reference Design	Part Number	Description
IRAC1150-D2	IR1150	One Cycle Control μ PFC Daughter Board
IRAC1150-300W	IR1150	PFC IC for use in continuous conduction mode boost converter applications designed for power factor correction and harmonic current reduction.
IRAC116-100W	IR1166	Synchronous rectification IC for use in 100W Flyback applications.

Appliance Reference Designs

International Rectifier offers the IRADK31 reference design for Appliance applications. This reference design kit includes a fully assembled and tested demo board along with applicable datasheets and application notes.



Featured Kits

IRADK31

1/4 HP DC brushless motor using IR31xx

- Featuring IR3101, IR3103 or IR3104
- 3-Phase 115-230V motor drive
- Opto-isolated RS-232 serial link interface to the GUI software.
- GUI Displays driver status, DC-link current, motor speed.
- GUI user settable parameters:
 - Motor operating speed
 - PWM frequency
 - Current Limit.

DC-DC Reference Designs

International Rectifier offers a wide range of reference designs for DC-DC applications. Each reference design kit includes a fully assembled and tested demo board along with applicable datasheets and application notes.



Featured Kits

IRDC2086-330W

Full bridge DC Bus Converter

- Featuring IR2086S full-bridge controller, IR6621, IR6635, IR6646 and IRF7380 MOSFETs
- For 2-stage onboard power distribution systems
- Smaller than 1/8 brick outline
- 97.2% efficiency with $48V_{IN}$ and $9.3V_{OUT}$ @ 35A



IRDC3623

2-Phase Dual Sync Buck with Oscillator Synchronization

- Featuring IR3623M PWM Controller
- iP2003A Power Block
- Pie-bias Startup
- Ideal for high current onboard DC to DC applications
- Programmable switching frequency up to 1.2 MHz
- $12V_{IN}$, $1.8V_{OUT}$ @ 60A each



IRPP3637-0X

Synchronous Buck Regulator for onboard DC to DC applications

- Featuring IR3637 PWM Controller
- $12V_{IN}$, $3.3V_{OUT}$ @ $18A I_{OUT}$
- 600 KHz switching frequency
- Programmable soft start
- Under voltage lockout

DC-DC ICs Reference Designs

Reference Design	Part Number	Description
IRDC2085S-DF	IR2085S	DC Bus Converter using IRF6603 secondary DirectFETs
IRDC2085S-S	IR2085S	DC Bus Converter using IRF7832 secondary FETs
IRDC2086-330W	IR2086S	Full bridge DC Bus Converter using IR2086S controller, IR6621, IR6635, IR6646 and IRF73830 FETs
IRDC2086S-DF	IR2086S	Full bridge DC Bus Converter using IRF7493 & IRF6603 FETs
IRDC3037	IRU3037	8-pin synchronous PWM controller, 200 KHz
IRDC3037A	IRU3037A	8-pin synchronous PWM controller, 400 KHz
IRDC3065	IRU3065	Positive to Negative Voltage Converter
IRDC3138	IRU3138	Low Cost Synchronous Buck Regulator for Voltage Tracking Applications
IRDC3621	IR3621M	Reference design kit featuring High Performance Dual Synchronous Buck Controller
IRDCiP1201-A	iP1201	2-phase, 30A, 3.14-5.5V _{IN} , 0.8-3.3V _{OUT} synchronous buck converter reference design
IRDCiP1202-A	iP1202	2-phase, 30A, 5.5-13.2V _{IN} , 0.8-3.3V _{OUT} synchronous buck converter reference design
IRDCiP1203-A	iP1203	1-phase, 15A, 5.5-13.2V _{IN} , 1.0-3.3V _{OUT} synchronous buck converter reference design
IRDCiP2003A-C	iP2003A	4-phase, 160A, 5-12V _{IN} , 0.8-3.3V _{OUT} 4MHz Switching Frequency multiphase buck converter reference design
IRPP3637-06A	IR3637	6A, 5V _{IN} / 1.25V _{OUT} , 600kHz featuring IR3637 dual synchronous buck controller
IRPP3637-12A	IR3637	12A, 12V _{IN} / 1.8V _{OUT} , 400kHz featuring IR3637 dual synchronous buck controller
IRPP3637-18A	IR3637	18A, 12V _{IN} / 3.3V _{OUT} , 600kHz featuring IR3637 dual synchronous buck controller



IRDCiP2003A-C

4-phase, 160A, 5-12VIN, 0.8-3.3VOUT 1MHz Switching Frequency multiphase buck converter reference design.

- Featuring iP2003A multiphase buck converter
- 160A, 5-12VIN, 0.8-3.3VOUT
- 1MHz switching frequency

Reference Designs **Fluorescent Reference Designs**

Fluorescent Reference Designs

International Rectifier offers a wide range of reference designs for Fluorescent Lighting applications. Each reference design kit includes a fully assembled and tested demo board along with applicable datasheets and application notes.

Featured Kits

IRPLMB1E

25W Small Sized Ballast, 220VAC Input

- Featuring IR2520D ballast controller IC
- Programmable run frequency & preheat time
- Open filaments and no-lamp protection
- Failure to Strike and deactivated-lamp protection
- Low AC line protection



IRPLCFL5E

CFL Ballast for 26W Spiral Lamp, 220VAC Input

- Featuring IR2520D ballast controller IC
- Programmable run frequency
- Open filaments and no-lamp protection
- Failure to Strike and deactivated-lamp protection



IRPLLNR7

Universal Input Linear Fluorescent Ballast for 35W TL5

- Featuring IRS2166D HVIC ballast controller
- High Power Factor/Low THD
- High Frequency Operation
- Lamp Filament Preheating
- Lamp Fault Protection with Auto-Restart

Reference Design	Part Number	Description
IRPLCFL2	IR2156	42W single, compact fluorescent lighting ballast, IR2156 100/220VAC
IRPLCFL3	IR2156	A ballast that can be dimmed from a domestic (phase cut) dimmer.
IRPLCFL4	IR2156	A 3-Way Dimming CFL Ballast
IRPLCFL5E	IR2520D	CFL Ballast for 26W/Spiral Lamp, 220VAC input
IRPLCFL5U	IR2520D	CFL Ballast for 26W/Spiral Lamp, 120VAC Input
IRPLMB1E	IR2520D	Mini-ballast for single 25W compact fluorescent ballast European version with 230VAC in
IRPLDIM2E	IR21571	Fully-integrated linear lighting ballast, IR21571, European version, 230VAC line, 36W/T8 lamp
IRPLDIM2U	IR21571	32W Fully-integrated linear lighting ballast, IR21571, U.S. version, 120VAC line, 32W/T8 lamp
IRPLLNR7	IRS2166D	Universal Input Linear Fluorescent Ballast using the IRS2166D

Reference Designs **Motion Control**

Motion Control Reference Designs

International Rectifier offers a number of reference designs for AC Induction or Brushless Motor motion control applications. Each reference design kit includes a fully assembled and tested demo board along with applicable datasheets and application notes.

Featured Kits

IRMD22381Q

A complete AC and brushless motor driver used with a 30A power module

- Featuring IR22381Q Three phase gate driver IC with advanced protection functions
- High Current Gate Driver for AC Induction or Brushless Motors
- Integrated desaturation detection circuit
- 1200V DC-Bus Capability up to 50A
- Compatible with standard ECONO2-6PACK IGBT module (Not included in design kit)



IRMD22141SS

High Current Gate Driver Reference design

- Featuring IR22141SS half bridge gate driver IC
- High Current Gate Driver for AC Induction or Brushless Motors
- Integrated desaturation detection circuit with active bias
- 1200V DC-Bus Capability up to 50A
- Compatible with standard ECONO2-6PACK IGBT module (Not included in design kit)



Reference Design	Part Number	Description
IRCS2277S	IR2277S	For 3-phase / 380V motor drives the IRCS2277S is designed to read 3-phase motor currents on top of pin-out compatible gate driver boards. The board can be used for both AC and Brushless motors current sensing by reading the voltage developed on shunt resistors.

RESOURCES



The IR Advantage

- KGD testing equal to package part testing
- 100% Avalanche capability for more than 75A
- Singulated testing, eliminating lateral current paths
- Accurate testing for $R_{DS(on)}$
- Voltage ratings up to 1200V
- Leakage current testing down to nA range
- Pogo pins provide accurate voltage and resistance readings
- Hybrid modifications enable cleaner noise environment
- Each die is warranted to be electrically good

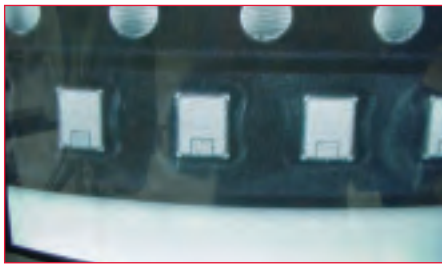

KGD package Options

T&R option:

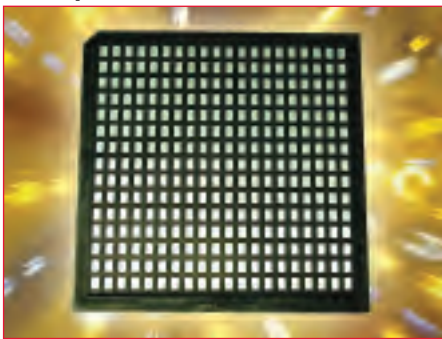

T&R dimensions are according to die Size.

Chip pack option:

Tray packaging option can be either 4" x 4" or 2" x 2" (outside dimensions).



International Rectifier's SureCHIP Program is a process regimen that combines high-volume manufacturing and assembly with precision parametric testing and special packaging to deliver Known Good Die (KGD) power semiconductors. The KGD process provides measurably higher yields and is an economically viable solution in the manufacturing of multi-chip modules (MCMs). As part of the SureCHIP process, individual good die from probed and sawn wafers are transferred to a custom-designed test nest for 100% electrical and visual testing.

SureCHIP power semiconductor die are packaged into tape and reel in a nitrogen atmosphere or into chip trays for shipment. The SureCHIP KGD process is qualified for 100% DC parametric testing. Additionally, avalanche testing on MOSFETs and short circuit testing on IGBTs can be performed.

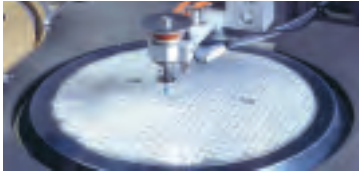

Individual Die from probed and sawn wafer are transferred to a custom designed test nest for electrical testing



SureCHIP is packaged in tape after passing 100% electrical testing and visual inspection



Die is fully tested in the proprietary test nest with the true Kelvin connections to enable measurements at high current

Sample Avalanche Test Results

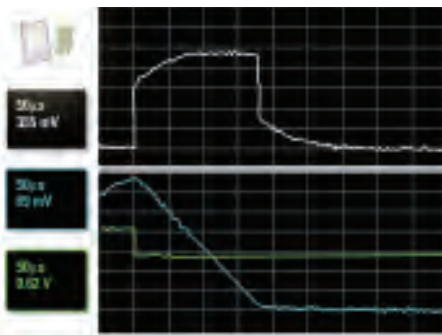

Comparison of Wafer Level Testing of $R_{DS(on)}$ vs. IR's KGD Solution

Wafer Level Testing

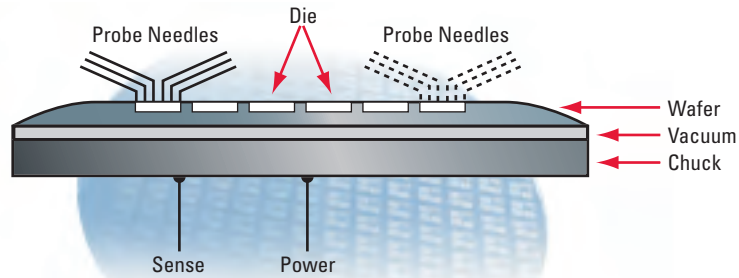

1. Multiple contacts between backside of wafer and chuck tester
2. Die to Die interference cannot be isolated
3. $R_{DS(on)}$ accurate down to $20m\Omega$
4. I_{DRAIN} measurements constrained to less than 10A
5. Parallel testing resulting in multiple signal paths that can effect results
6. Key measurements impacted by Kelvin contacts over entire backside of wafer
7. High risk for final application due to dicing operation

IR's KGD Level Testing

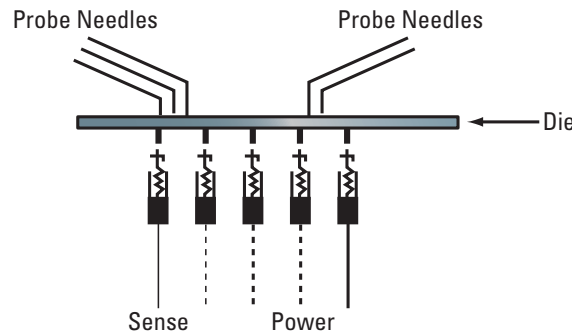

1. Pogo pins provide uniform contact
2. Direct contact with isolated Die
3. $R_{DS(on)}$ accurate down to $2.5m\Omega$
4. I_{DRAIN} Measurements possible to greater than 75A
5. Singulated testing, eliminating lateral current paths
6. Hybrid modifications enable cleaner noise environment
7. Kelvin contact fixed to single location for single die
8. Singulated die usually pre-screened for mechanical defects

The myPOWER Advantage

- Eliminates simulation model development by giving access to a fully developed, highly accurate and FREE model
- Eliminates the delay in building breadboards and most breadboarding iterations
- Enables more robust designs optimized for cost and performance
- Saves 1 to 6 months in development time and thousands of dollars in development cost

DESIGN TOOL SELECTIONS



Power Factor Correction

Simple circuit design
Calculate all part values
Reduce PCB space 50%

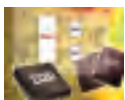

Point of Load

Simulate iPower circuits
Compare discrete MOSFETs
Calculate efficiency and Tj



Motor Control

Analyze performance
Compare IGBT modules
Calculate efficiency and Tj



Synchronous Rectification

Improve circuit efficiency
Compare MOSFET choices
Calculate all part values



Bus Converter

Multiple Topologies
Compare discrete MOSFETs
Calculate efficiency and Tj



Lighting

Create Schematic and BOM
Display output waveforms
AC or DC input Designs



- Simulate Circuits
- Analyze Waveforms
- Compare MOSFETS
- Calculate Losses

Designing DC-DC converters for advanced NPU or CPU is becoming increasingly complex. Now you have an alternative to starting your new design from scratch.

Try the myPOWER on-line design center: it is one place dedicated to the design of high performance DC-DC converters operating at up to 80A at V_{OUT} as low as 1.1V and at frequencies as high as 1 MHz.

myPOWER gives you a proven design with a complete, costed BOM and a high speed, +/-5% accuracy simulation tool to verify and optimize your circuit. And you can order a customized reference design kit for overnight delivery.



CEO's Message

“International Rectifier is dedicated to providing a safe and healthful workplace with responsible environmental practices essential to the success of our business, while preserving our environment for future generations. As global leaders in power management, our expertise in energy conservation branches out to include all aspects of environmental health and safety in making the planet a better place to live.”

Alexander Lidow, Ph.D.

Chief Executive Officer

Global Environmental, Health, and Safety Policy

International Rectifier is committed to protecting and preserving the environment in all its business operations and providing a safe and secure workplace. It is our intent to respect the views of our customers, employees, community, and stakeholders as a responsible business dedicated to continual improvement in environmental, health and safety management and the prevention of pollution.

Consistent with our values, principles, and policies, we pledge to:

- Encourage the efficient use of electricity by improving the power conversion process through the development of innovative products.
- Comply with all applicable laws and regulations, and consider any other requirements to which we subscribe.
- Ensure policy performance by stating objectives and setting clear targets for their achievement as part of the Annual Business Planning process.
- Review our EH&S management system to assure its continued applicability and effectiveness through periodic assessments and audits.
- Help conserve natural resources through additional cost-effective reuse, recycling, and reduction efforts in existing and future operations.
- Foster a safe and secure work environment by increasing employee knowledge and awareness of environmental, health and safety best practices.
- Communicate the Policy to all employees, stakeholders, and make it available to the public.

Stewardship

Creating Environmental Value - International Rectifier is dedicated to providing an environmentally sustainable future by creating environmental value through our product designs and reducing our local and global environmental footprint through a management culture that integrates environmental goals into the decision making model

- IR designs and manufactures power management products that save energy, providing leadership to an environmentally sustainable future.
- Reducing our footprint on the local and global environment by having environmental goals as part of our annual business planning process.
- ISO14001 Certifications

Online Self Support

Technical Documents

- Electronics 101 tutorial
- Application notes
- Technical papers
- Design tips
- FAQ's

Design Support

- Software Design Tools
 - MyPower, with two primary sections, MOSFET selector tool & iPowir Sync Buck Simulator
 - HEXRISE Temperature Rise Calculator
 - DirectFET Thermal Rating Calculator
 - Ballast Design Assistant (BDA) software
 - Spice & Saber Models
- Reference design kits
- Design tips

Product Information

- Parametric Search
- Product Line
- New Products
- Cross & Replacement
- Lead Free
- Product Packaging
- Product Literature
- Quality & Reliability
- Samples & Sales



Our mission as a global Technical Assistance Center

Our mission as a global Technical Assistance Center is to provide quality prompt solutions to customer inquiries. In addition to self-support material available on our website qualified application engineers are available to address your questions by email/online or by phone. Our global presence allows for a continuous 24 hours operation, enabling us to resolve most inquiries within the first business day.

In line with the rapid expansion of IR's proprietary product line, regular up to date training is provided for the TAC staff to ensure quality of support. Additional technical documentation such as application notes and design tips are generated to further encourage online self-support and to reduce resolution time.

TAC Support Channels

- Direct Customers
- IR Sales Reps
- Internal IR Employees
- Distributors
- FAEs

Types of Technical Inquiries Supported by TAC

- Assistance with Design-In of IR Technologies
- Recommendation of Proprietary Product Solutions
- Identification/Verification of Part numbers
- Applications Assistance
- Trouble shooting customer designs
- Product Selection
- Verification of Product datasheet Parameters
- Cross Reference to Competitor Parts
- Recommendations of Upgrades to Obsolete Parts

Value Added for our Customers

- Global Real Time Support
 - Online & Email
 - Phone & Fax
- Real time literature Support
- Online Software Design Support
- Technical Training Modules
- Tradeshows



How to find Technical Support on the International Rectifier main webpage:



How to submit a question online:



Using the following interface questions along with related attachments (e.g. schematics) can be submitted. Upon successful submission of a question the system will issue an incident tracking number.



“My Stuff” Tab allows to update or to check the status of an incident. This tab also enables the use to answer update notifications, and edit account profile.



Using the FAQ tab you may view our extended online knowledge base:

Channels of Contact

Online: <http://tac.irf.com>

E-mail: tac@irf.com

Phone Numbers:

North America

Hours: 8:00AM-5:00PM PST

Tel: 310-252-7105

Fax: 310-252-7903

Europe:

Hours: 8:30AM-5:30PM GMT

Tel: ++ 44-0-1737-227-215

Fax: ++ 44-0-1737-227-286

Asia, China (Shenzhen)

Hours: 9:00AM-6:00PM CST

Tel: ++ 86-755-8329-6861

Fax: ++86-755-8329-6862

Asia, China (Shanghai)

Hours: 9:00AM-6:00PM CST

Tel: ++ 86-21-5877-5606

Fax: ++ 86-21-5877-3880

Asia, Korea (Seoul)

Hours: 9:00AM-6:00PM CST

Tel: ++ 82-255-74332

Germany

Hours: 9:00AM-4:00PM CET

Tel: ++ 49-6102-884-310

Fax: ++ 49-6102-884-433

INDEX



IP1201	p 24	IR2172S	p 17	IRDC2085S-DF	p 57
IP1202	p 24	IR2175	p 17	IRDC2085S-S	p 57
IP1203	p 24	IR2175S	p 17	IRDC2086-330W	p 57
IP2001	p 25	IR21771S	p 17	IRDC2086S-DF	p 57
IP2002	p 25	IR2177S	p 17	IRDC3037	p 57
IP2003	p 25	IR2213	p 23	IRDC3037A	p 57
IP2003A	p 25	IR2214	p 22	IRDC3038	p 57
IPS1011	p 38	IR22381	p 22	IRDC3039	p 57
IPS1011R	p 38	IR2238	p 22	IRDC3046	p 57
IPS1011S	p 38	IR22771S	p 17	IRDC3048	p 57
IPS1021	p 38	IR2277S	p 17	IRDC3055	p 57
IPS1021R	p 38	IR2520D	p 26	IRDC3065	p 57
IPS1021S	p 38	IR2520DS	p 26	IRDC3073	p 57
IPS1031	p 38	IR2520S	p 26	IRDC3137	p 57
IPS1031R	p 38	IR3082AM	p 33	IRDC3138	p 57
IPS1031S	p 38	IR3082M	p 33	IRDC3146	p 57
IPS10416pbf	p 38	IR3084MPBF	p 33	IRDC3621	p 57
IPS1041Rpbf	p 38	IR3086AM	p 33	IRDC3624	p 57
IPS51Lpbf	p 38	IR3087	p 33	IRDC3637	p 57
IPS1042Gpbf	p 38	IR3088A	p 33	IRDC5001-LS370W	p 57
IPS2041Lpbf	p 38	IR3092M	p 32	IRDC5001-LS48V	p 57
IPS2041Rpbf	p 38	IR3093M	p 32	IRDCIP1001-A	p 57
IPS6011Pbf	p 38	IR3094MPBF	p 32	IRDCIP1001-B	p 57
IPS6011Rpbf	p 38	IR3101	p 36	IRDCIP1201-A	p 57
IPS6011Spbf	p 38	IR3310	p 39	IRDCIP1202-A	p 57
IPS6021pbf	p 38	IR3310S	p 39	IRDCIP1203-A	p 57
IPS6021Rpbf	p 38	IR3311	p 39	IRDCIP2001-A	p 57
IPS6021Spbf	p 38	IR3311S	p 39	IRDCIP2001-B	p 57
IPS6041Gpbf	p 38	IR3312	p 39	IRDCIP2001-C	p 57
IPS6041Rpbf	p 38	IR3312S	p 39	IRDCIP2002-C	p 57
IPS6041Spbf	p 38	IR3313PBF	p 38, 39	IRDCIP2003A-C	p 57
IPS7091Gpbf	p 38	IR3313S	p 38, 39, 40	IRF1010EZS	p 45
IPS7071G	p 38	IR3313SPBF	p 39, 40	IRF1010Z	p 45
IPS7081pbf	p 38	IR3314PBF	p 38, 39, 40	IRF1010ZS	p 45
IR1150	p 14, 30, 31	IR3314SPBF	p 38, 39, 40	IRF13245-7PPBF	p 50
IR1150I	p 14	IR3315PBF	p 38, 39, 40	IRF1404ZS	p 45
IR1150IS	p 14	IR3315SPBF	p 38, 39, 40	IRF1405ZS	p 45
IR1150S	p 14	IR3316S	p 38, 39, 40	IRF1405ZS-7P	p 45
IR1167ASPBF	p 12	IR3621F	p 32	IRF2804S	p 45
IR2085S	p 11	IR3621M	p 32	IRF2804S-7P	p 45
IR2086S	p 11	IR3623MPBF	p 32	IRF2807ZS	p 45
IR21141SS	p 22	IR3624MPBF	p 32	IRF2903Z	p 45
IR2114SS	p 22	IR3637ASPBF	p 32	IRF2907ZS	p 45
IR21381	p 22	IR3637SPBF	p 32	IRF3205ZS	p 45
IR2156	p 26	IRAC1150-300W	p 55	IRF3305	p 45
IR2156S	p 26	IRAC1150-D2	p 55	IRF3307	p 45
IR2157	p 26	IRAC1166-100W	p 55	IRF3507	p 45
IR21571	p 26	IRAMS06UP60A	p 36	IRF3704	p 50
IR21571S	p 26	IRAMS06UP60B	p 36	IRF3704L	p 50
IR2157S	p 26	IRAMS10UP60A	p 36	IRF3704S	p 50
IR2161	p 28, 29	IRAMS10UP60B	p 36	IRF3704Z	p 50
IR2161S	p 28, 29	IRAMX16UP60A	p 36	IRF3704ZCL	p 50
IR2166	p 26	IRAMX16UP60B	p 36	IRF3704ZCS	p 50
IR2166S	p 26	IRAMX20UP60A	p 36	IRF3704ZL	p 50
IR2171	p 17	IRAMY20UP60B	p 36	IRF3704ZS	p 50
IR2171S	p 17	IRAUDAMP3	p 16	IRF3707	p 50
IR2172	p 17	IRCS2277S	p 59	IRF3707L	p 50

Index

IRF3707S	p 50	IRF6668	p 47	IRFZ44ZS	p 45
IRF3707Z	p 50	IRF6678	p 47	IRFZ46ZS	p 45
IRF3707ZCL	p 50	IRF6691	p 47	IRFZ48ZS	p 45
IRF3707ZCS	p 50	IIRF6716MTRPBF	p 47	IRGB20B60PD1	p 35
IRF3707ZL	p 50	IRF7380	p 48	IRGB4056DPBF	p 34, 44
IRF3707ZS	p 50	IRF7413Z	p 51	IRGB4059DPBF	p 44
IRF3709	p 50	IRF7492	p 51	IRGB4060DPBF	p 44
IRF3709L	p 50	IRF7493	p 51	IRGB4061DPBF	p 34
IRF3709S	p 50	IRF7494	p 51	IRGB4062DPBF	p 34, 44
IRF3709Z	p 50	IRF7495	p 51	IRGB4064D	p 44
IRF3709ZCL	p 50	IRF7805Z	p 51	IRGP20B60PD	p 35
IRF3709ZCS	p 50	IRF7807Z	p 51	IRGP35B60PD	p 35
IRF3709ZL	p 50	IRF7821	p 51	IRGP4056D	p 44
IRF3709ZS	p 50	IRF7823	p 51	IRGP4060D	p 44
IRF3711	p 50	IRF7831	p 51	IRGP4061D	p 44
IRF3711L	p 50	IRF7832	p 51	IRGP4062DPBF	p 34
IRF3711S	p 50	IRF7832Z	p 51	IRGP4068DPBF	p 44
IRF3711Z	p 50	IRF7834	p 51	IRGP50B60PD	p 35
IRF3717	p 51	IRF7835	p 51	IRGR3B60KD2	p 34
IRF3805S-7P	p 45	IRF7836	p 51	IRL1404ZS	p 45
IRF3805ZS-7P	p 45	IRF7842	p 51	IRL3705ZS	p 45
IRF4104S	p 45	IRF7853PBF	p 12, 51	IRL3714	p 50
IRF540ZS	p 45	IRF7854PBF	p 12, 51	IRL3714L	p 50
IRF6100	p 49	IRF7855PBF	p 12, 51	IRL3714S	p 50
IRF6608	p 47	IRF7902PBF	p 48	IRL3714Z	p 50
IRF6609TRPBF	p 47	IRF7904PBF	p 48	IRL3714ZL	p 50
IRF6610TRPBF	p 47	IRF7905PBF	p 48	IRL3714ZS	p 50
IRF6611TRPBF	p 47	IRF7907PBF	p 48	IRL3715	p 50
IRF6612TRPBF	p 47	IRF8113	p 51	IRL3715L	p 50
IRF6613TRPBF	p 11, 47	IRF8910	p 48	IRL3715S	p 50
IRF6614TRPBF	p 47	IRF8915	p 48	IRL3715Z	p 50
IRF6616TRPBF	p 47	IRFB3206PBF	p 12, 50	IRL3715ZCL	p 50
IRF6617TRPBF	p 47	IRFB3207	p 12, 50	IRL3715ZCS	p 50
IRF6618TRPBF	p 47	IRFB3207ZPBF	p 12, 50	IRL3715ZL	p 50
IRF6619TRPBF	p 47	IRFB3306PBF	p 12, 50	IRL3715ZS	p 50
IRF6620TRPBF	p 47	IRFB3307	p 12	IRL7833	p 50
IRF6621TRPBF	p 47	IRFB4110PBF	p 12	IRL7833L	p 50
IRF6622TRPBF	p 47	IRFB4227PBF	p 12	IRL7833S	p 50
IRF6623TRPBF	p 47	IRFB4310	p 12	IRL8113	p 50
IRF6626TRPBF	p 47	IRFB4321PBF	p 12	IRL8113L	p 50
IRF6628TRPBF	p 47	IRFL024Z	p 45	IRL8113S	p 50
IRF6629TRPBF	p 47	IRFR120Z	p 45	IRLL024Z	p 45
IRF6631TRPBF	p 47	IRFR2307Z	p 45	IRLR024Z	p 45
IRF6633TRPBF	p 47	IRFR2607Z	p 45	IRLR2905Z	p 45
IRF6635TRPBF	p 11	IRFR2905Z	p 45	IRLR3705Z	p 45
IRF6635TRPBF	p 47	IRFR4105Z	p 45	IRLR3714Z	p 48
IRF6636TRPBF	p 47	IRFR467	p 45	IRLR3715Z	p 48
IRF6637TRPBF	p 47	IRFR48Z	p 45	IRLR3717	p 48
IRF6638TRPBF	p 47	IRFR540Z	p 45	IRLR3915	p 48
IRF6641TRPBF	p 47	IRFS4310	p 45	IRLR7807Z	p 48
IRF6644TRPBF	p 11, 47	IRFS4410	p 45	IRLR7821	p 48
IRF6645TRPBF	p 47	IRFS4610	p 45	IRLR7833	p 48
IRF6646TRPBF	p 11, 47	IRFU3704Z	p 48	IRLR7843	p 48
IRF6648TRPBF	p 47	IRFU3707Z	p 48	IRLR8113	p 48
IRF6655TRPBF	p 11, 47	IRFU3709Z	p 48	IRLR8711PBF	p 48
IRF6662TRPBF	p 47	IRFU3711Z	p 48	IRLR8713PBF	p 48
IRF6665		IRFZ44VZS	p 45	IRLR8715PBF	p 48

IRLU3714Z	p 48	PVA3054N	p 42	PVT322AS	p 43
IRLU3715Z	p 48	PVA3054NS	p 42	PVT322S	p 43
IRLU3717	p 48	PVA3055N	p 42	PVT412	p 43
IRLU7807Z	p 48	PVA3055NS	p 42	PVT412A	p 43
IRLU7821	p 48	PVA3324N	p 42	PVT412AS	p 43
IRLU7833	p 48	PVA3324NS	p 42	PVT412L	p 43
IRLU7843	p 48	PVA3354N	p 42	PVT412LS	p 43
IRLU8113	p 48	PVA3354NS	p 42	PVT412S	p 43
IRLU8711PBF	p 48	PVAZ172N	p 42	PVT422	p 43
IRLU8713PBF	p 48	PVAZ172NS	p 42	PVT422P	p 43
IRLU8715PBF	p 48	PVD1352N	p 41	PVT422S	p 43
IRLZ44ZS	p 45	PVD1352NS	p 41	PVU414	p 43
IRMCF311	p 18	PVD1354N	p 41	PVU414S	p 43
IRMCF312	p 18	PVD1354NS	p 41	PVX6012	p 43
IRMCF341	p 18	PVD2352N	p 41, 42	PVY116	p 43
IRPLCFL2	p 27, 58	PVD2352NS	p 41, 42	PVY117	p 43
IRPLCFL3	p 27, 58	PVD3354N	p 41, 42		
IRPLCFL4	p 27, 58	PVD3354NS	p 41, 42		
IRPLCFL5E	p 27, 58	PVDZ172N	p 41		
IRPLCFL5U	p 27, 58	PVDZ172NS	p 41		
IRPLDIM1E	p 58	PVG612	p 42		
IRPLDIM1U	p 58	PVG612A	p 42		
IRPLDIM2E	p 27, 58	PVG612AS	p 42		
IRPLDIM2U	p 27, 58	PVG612S	p 42		
IRS2001PBF	p 23	PVG613	p 42		
IRS2003PBF	p 23	PVG613S	p 42		
IRS2003SPBF	p 23	PVI1050N	p 43		
IRS2004PBF	p 23	PVI1050NS	p 43		
IRS2004SPBF	p 23	PVI5013R	p 43		
IRS2011PBF	p 16	PVI5013RS	p 43		
IRS2011SPBF	p 16	PVI5033R	p 43		
IRS20124S	p 16	PVI5033RS	p 43		
IRS20955SPBF	p 16	PVI5050N	p 43		
IRS2101PBF	p 21, 31	PVI5050NS	p 43		
IRS2103	p 23	PVI5080N	p 43		
IRS2103S	p 23	PVI5080NS	p 42		
IRS2104	p 31	PVN012	p 42		
IRS2106	p 23	PVN012APBF	p 42		
IRS21064	p 23	PVN012ASPBF	p 42		
IRS2108	p 23	PVN012S	p 42		
IRS21084S	p 23	PVN013	p 42		
IRS2109	p 23, 31	PVN013S	p 42		
IRS21094	p 23	PVO402AP	p 42		
IRS2110-1PBF	p 23	PVO402P	p 42		
7IRS2111PBF	p 23	PVR1300N	p 42		
IRS2112-1PBF	p 23	PVR1301N	p 42		
IRS2113-1PBF	p 23	PVR2300N	p 42		
IRS2117PBF	p 30, 31	PVR3300N	p 42		
IRS2118PBF	p 30	PVR3301N	p 42		
IRS21303D	p 21	PVT212	p 42		
IRS2130D	p 21	PVT212S	p 42		
IRS2132D	p 21	PVT312	p 42		
IRS2133DPBF	p 21	PVT312L	p 42		
IRS2135DPBF	p 21	PVT312LS	p 42		
IRS2136DPBF	p 21	PVT312S	p 42		
IRS21362D	p 21	PVT322	p 43		
IRS2153DPBF	p 26, 29	PVT322A	p 43		

GLOBAL LOCATIONS

WORLD HEADQUARTERS

International Rectifier Corporation
233 Kansas Street
El Segundo, CA 90245
Phone: (310) 726-8000
Fax: (310) 322-3332
Internet: www.irf.com

NORTH AMERICAN OPERATIONS

HEXFET America
41915 Business Park Drive
Temecula, CA 92590
Phone: (951) 676-7500
Fax: (951) 676-9154

International Rectifier HiRel Products, Inc.
2270 Martin Avenue
Santa Clara, CA 95050
Phone: (408) 727-0500
Fax: (408) 988-2702

International Rectifier HiRel Products, LLC
205 Crawford Street
Leominster, MA 01453
Phone: (978) 534-5776
Fax: (978) 537-4246

Branch Sales Office – U.S.A.
41700 Gardenbrook, Suite 110
Novi, MI 48375
Phone: (248) 347-1830
Fax: (248) 347-6388

Rectificadores Internacionales,
S.A. de C.V.
Prolongacion Ave.
Los Cabos No. 9234
Parque Industrial Pacifico II
C.P. 22709
Tijuana, Baja California, Mexico
Phone: (+) 52 66 46 26 08 04
Fax: (+) 52 66 46 26 01 02

EUROPEAN OPERATIONS

International Rectifier Company
(Great Britain) Ltd.
The Omnibus Building
Lesbourne Road
Reigate, Surrey
RH2 7JP, United Kingdom
Phone: (+) 44 1737 227200
Fax: (+) 44 1737 227201

IR Newport Limited
Cardiff Road
Newport, NP10 8YJ, Wales,
United Kingdom
Phone: (+) 44 1633 810 121
Fax: (+) 44 1633 810 820

Branch Sales Office – Denmark
Bagsvaerdvej 70A
DK-2800, Lyngby (Copenhagen)
Phone: (+) 45 45 28 06 96
Fax: (+) 45 45 28 19 96

Branch Sales Office – France
Immeuble Zeta
3 Avenue du Canada
LP817 - Batiment Zeta
91974 Courtaboeuf Cedex, France
Phone: (+) 33 1 64 86 49 50
Fax: (+) 33 1 64 86 49 70

International Rectifier GmbH
Frankfurter Strasse 227
D-63263 Neu-Isenburg Germany
Phone: (+) 49 6102 884 400
Fax: (+) 49 6102 884 433

International Rectifier Corporation Italiana, S.p.A.
Via Liguria 49, 10071 Borgaro,
Torino (To), Italy
Phone: (+) 39 011 451 0111
Fax: (+) 39 011 451 0220

Branch Sales Office – Italy
Via le Brianza, 20
20092 Cinisello Balsamo, Milan
Phone: (+) 39 02 61 24 18 11
Fax: (+) 39 02 61 24 18 23

IR International Holdings, Inc.
Moscow Representative Office
Office 407, Semenovsky pereulok
107023, Moscow, Russia
Phone/Fax: (+) 7 095 964 9560

ASIAN OPERATIONS

International Rectifier Japan Company, Ltd.
Sunshine 60 Building, 51st Floor
3-1-1, Higashi-Ikebukuro
Toshima-ku, Tokyo, 170-6051 Japan
Phone: (+) 81 3 3983 0641
Fax: (+) 81 3 3983 4856

Branch Sales Office – Nagoya, Japan
Meitetsu Kanayama Daiichi Bldg. 5F
25-1 Namiyose-cho Atsuta-ku
Nagoya-shi, Aichi 456-0003
Phone: (+) 81 52 871 0570
Fax: (+) 81 52 871 0576

Branch Sales Office – Osaka, Japan
KAZU IT Bldg.
2-10-27 Minami-Semba
Chuo-ku, Osaka-Shi,
Osaka 542-0081
Phone: (+) 81 6 6258 7560
Fax: (+) 81 6 6258 7561

International Rectifier Hong Kong, Ltd.
Unit 308, New East Ocean Centre
No. 9 Science Museum Road
Tsimshatsui East, Kowloon
Hong Kong
Phone: (+) 852 2803 7380
Fax: (+) 852 2540 5835

IR International Holdings, Inc.
Beijing Representative Office
Canway Building, Suite 710
66 Nan Li Shi Road, Xi Cheng District
Beijing, 100045, China
Phone: (+) 86 10 6803 8195
Fax: (+) 86 10 6803 8194

Shanghai Representative Office
Unit A-C, 10th Floor
Xinmei Union Square
999 Pudong South Road
Shanghai, 200120, China
Phone: (+) 86 21 68877600
Fax: (+) 86 21 58773880

Shenzhen Representative Office
31 C, Block C
Electronics Science
& Technology Building
2070 Shennan Road
Shenzhen, 518031, China
Phone: (+) 86 755 8368 3686
Fax: (+) 86 755 8368 3690

Taiwan Representative Office
22F Suite A, 105, Section 2
Tun Hwa South Road
Taipei 106, Taiwan, R.O.C.
Phone: (+) 886 2 2709 8356
Fax: (+) 886 2 2709 8150

Philippines Representative Office
Suite 2008, 20F, Strata 100 Building
Emerald Avenue
Ortigas Center, Pasig City,
Metro Manila
1605 Philippines
Phone: (+) 632 633 7882
Fax: (+) 632 631 6661

International Rectifier Korea
9F, Dukmyung Building
170-9 Samsung-Dong, Kangnam-Gu
Seoul, 135-741 Korea
Phone: (+) 82 2 557 7613
Fax: (+) 82 2 557 7617

International Rectifier
Southeast Asia Pte. Ltd.
1 Kim Seng Promenade #13-11
Great World City West Tower
Singapore 237994
Phone: (+) 65 6838 4600
Fax: (+) 65 6733 7995

India Liaison Office
International Rectifier Corporation
407 Prestige Centre Point
Cunningham Road
Bangalore 560 052, India
Phone: (+) 91 80 4114 2644/2645
Fax: (+) 91 80 4114 2643

International
IOR Rectifier

THE POWER MANAGEMENT LEADER