

# PSoC® PROGRAMMABLE SYSTEM-ON-CHIP

HIGHER INTEGRATION, FASTER TIME-TO-MARKET, GREATER EMBEDDED DESIGN FLEXIBILITY.

DESIGN WITHOUT  
CONSTRAINTS



## DESIGN FREEDOM. BREAKTHROUGH TECHNOLOGY.



You're not waiting for the next big thing to come along. You're designing it. Cypress's PSoC® programmable system-on-chip platform gives you the freedom to imagine revolutionary new products and the capability to get to market faster than anyone else.

PSoC is a true **programmable embedded SoC** integrating configurable analog and digital peripheral functions, memory and a microcontroller on a single chip. With an extremely flexible visual embedded design methodology that includes preconfigured, user-defined peripherals and hierarchical schematic entry, you can change your mind as often as you want and stay on schedule. No more restarting projects from scratch. No more catalogs. No more limitations.

### INTRODUCING NEW PSoC ARCHITECTURES

And now our breakthrough new **PSoC 3 and PSoC 5** architectures extend the world's only programmable embedded system design platform, shattering your design limitations. Take advantage of high-precision programmable analog including 12- to 20-bit delta-sigma ADCs, a digital logic library with dozens of drop-in peripherals, best-in-class power management and rich connectivity resources. Implement your 8-, 16-, or 32-bit designs with the high-performance 8051 or advanced ARM® Cortex™-M3 processors.

With Cypress's PSoC programmable system-on-chip, the possibilities are endless. It's breakthrough design without constraints.

# PSoC: ONE PLATFORM, THREE ARCHITECTURES

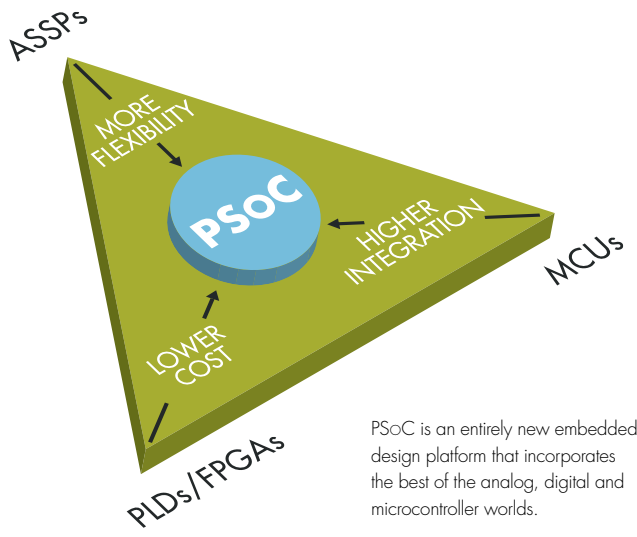

PSoC is an entirely new embedded design platform that incorporates the best of the analog, digital and microcontroller worlds.

Cypress's scalable PSoC platform **adapts to your design needs**, so you don't have to constantly change your design to accommodate different MCU architectures.

Using PSoC's flexible design software, you can create custom chips in hours rather than months, at a fraction of the cost of traditional processes. Create the mix of peripherals you want on your chip, select whichever pin you want, and you're done—at least until someone changes the specs. Even then, with PSoC, you only have to add or change a block to accommodate late alterations. You don't have to start from scratch or go back to the catalog to select a new MCU or discrete peripherals. Sure, change orders will still be annoying, but with PSoC, there won't be a major delay to your project schedule.

## PSoC 1

Get performance, programmability and flexibility with a cost-optimized 8-bit M8C CPU subsystem. Easy-to-use design software makes creating embedded solutions fast, with little or no code required.

## PSoC 3

A single-cycle, pipelined 8-bit 8051 core and a high-performance configurable digital system provide unmatched analog and digital BOM integration with the flexibility to handle late design changes anywhere in the design process.

## PSoC 5

Larger, more complex applications are easily handled by the PSoC 5 architecture, with its 32-bit 80 MHz ARM Cortex-M3 processor. Incorporate more complex applications like audio, video, and motor control—anything you can imagine.

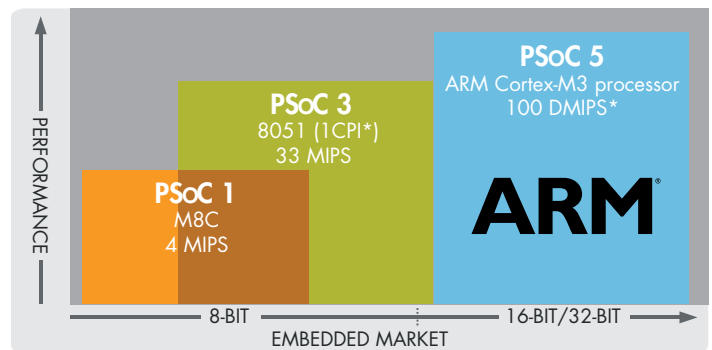

The PSoC platform offers unparalleled design flexibility and a wide performance range for your 8-, 16-, or 32-bit designs.

FEATURE	PSoC 1	PSoC 3	PSoC 5
INTERFACE	SPI, UART, GPIO FS-USB, I <sup>2</sup> C	PSoC 1, plus: CAN, I <sup>2</sup> S	Same as PSoC 3
INPUTS	Sensors, CapSense, touchscreen, analog	PSoC 1, plus: precision analog	PSoC 3, plus: high-speed analog
OUTPUTS	LED control, motor control, analog buffers	PSoC 1, plus: LCD segment drive, LED drive, advanced motor control	PSoC 3, plus: QVGA LCD control
PROCESSING	M8 24 MHz	8051 67 MHz	ARM® Cortex™-M3 processor 80 MHz

\*DMIPS = Dhrystone MIPS.  
\*CPI = Cycles per instruction.

## FUNCTIONS ENABLED BY PSoC

- **Environmental sensing**
  - Pressure
  - Humidity
  - Current
  - Airflow
  - Acceleration
  - Tilt
  - Pyroelectric Infrared (PIR)
  - Light
  - Voltage
  - Temperature
  - Inductive
  - Gas
  - Liquid level
- **Touch Sensing**
  - CapSense capacitive sensing (buttons, sliders)
  - Touchscreens
  - Trackpads
  - Proximity sensing
- **Fan/Motor Control**
  - AC motor
  - DC motor
  - Fan
  - Fuel pump
  - Instrument gauges
- **Communications interfaces**
  - Wireless radio control
  - LIN bus
  - Optical cable conversion
  - Dual Tone Multi-Frequency (DTMF) dialer
  - USB 2.0
- **Power Control**
  - Battery charging
  - Voltage & current
  - System power
  - AC power metering
  - Lighting
- **Other**
  - Magnetic card read/write
  - Mechanical buttons or other inputs
  - LCD display/drive control
  - LED drive

# THE PERFORMANCE PILLARS: FLEXIBILITY, INTEGRATION, PROGRAMMABLE ANALOG

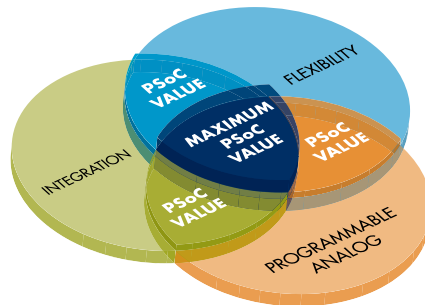

**A BETTER WAY TO DESIGN:** Whether you take advantage of just one or all of PSoC's three pillars of performance, you'll realize significant design benefits.

Cypress's PSoC programmable system-on-chip removes the barriers you face with fixed-function MCUs and discrete analog/digital components by providing an unparalleled combination of flexibility, integration, and analog functionality.

## FLEXIBILITY

You work in an environment where change is the only constant. Programmable analog and digital blocks in PSoC give you the flexibility to adapt to changing requirements quickly and easily, while designing products that specifically meet market demands.

- Add new features
- Differentiate your products
- Tune and adjust your designs during debug/system bring-up

## INTEGRATION

Unmatched integration makes PSoC the fastest way to reduce the size, weight, and power requirements of your product. Dynamic reconfiguration lets you reduce testing costs by enabling dynamically configurable board self-tests. Additionally, one PSoC integrates as many as 100 peripheral functions, so you can:

- Reduce BOM costs
- Maximize functionality
- Improve reliability
- Streamline manufacturing

## PROGRAMMABLE ANALOG

Developing embedded systems with advanced analog sensing, monitoring, and control is simple with PSoC's built-in, high-precision programmable analog features and powerful visual embedded design tool. The PSoC solution includes a broad portfolio of preconfigured and characterized user components for:

- CapSense™ capacitive touch sensing
- Voltage monitoring
- Environmental sensing
- Fan/motor control



WITH DISCRETE COMPONENTS

WITH PSoC

**INTEGRATION:** In this communications product, PSoC technology reduced the BOM from 12 ICs to 3 by integrating FSK detection, voltage monitoring, DTMF, and ringtone generation.

# PSoC BUILDS SYSTEM VALUE

## SAVE MONEY ON DEVELOPMENT AND MANUFACTURING

- Reduce R&D costs and cycle time with technology that doesn't force you to lock in design specifications up front.
- Eliminate or reduce debugging and minimize coding, with pre-characterized, pre-verified modules and components.
- Reuse designs across platforms.
- Cut manufacturing, assembly, and test costs by shrinking PCBs.

## MAKE MORE MONEY, FASTER

- Get to market *fast* with feature-rich products that sell at a premium.
- Get to market *first*, capturing higher-margin early-adopters and selling more units over time.

## PROTECT YOUR INVESTMENT AND YOUR ASSETS

- Future-proof your products with field-upgradable PSoC technology, reducing costly, troublesome service calls.
- Create competitive barriers to entry with scalable designs.
- Protect your IP by making your designs harder to reverse-engineer.

The more innovative the design, the more likely it is to be copied. Unlike discrete components, or fixed-function peripherals, PSoC devices integrate and conceal key analog and digital components within a single chip. Thus, they are harder to reverse-engineer, making copying prohibitively expensive.

## WITH THE PSoC PLATFORM YOU CAN:

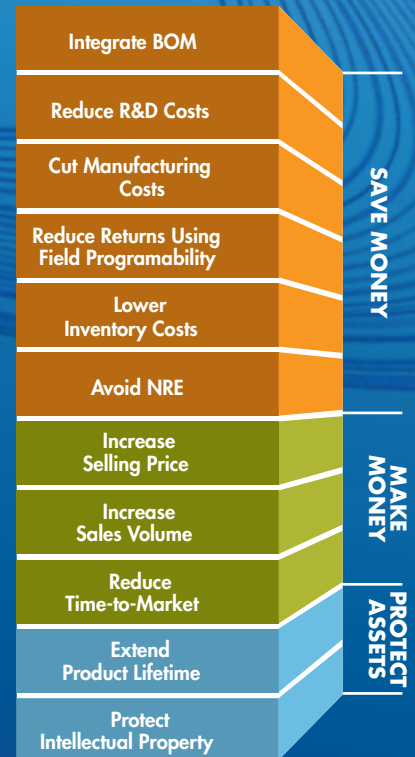

PSoC technology helps you optimize and differentiate your design, shorten time-to-market and cut engineering costs to improve your profitability.



# 1/2 BILLION PSoC DEVICES SHIPPED

# PSoC: THE PROGRAMMABLE SYSTEM-ON-CHIP

## INNOVATION STARTS HERE

Cypress's PSoC programmable system-on-chip platform provides a rich array of enabling technologies: analog and digital "building blocks," industry-standard processors and interfaces that give you the ability to create precisely the chip that you need.

With PSoC 1, PSoC 3, and PSoC 5, you choose from a library of predefined and tested IP functions that free you to develop new features for your product and get to market faster, gaining a distinct competitive advantage in the market.

### Integrated LCD Drive Technology

can drive up to 736 LCD segments with no external devices. PSoC's on-board voltage boost technology enables 3V to 5V LCD glass to be driven from a 0.5V power source.

### High-Precision Programmable Analog.

Up to 20-bit precision with reference voltage accuracy better than  $\pm 0.1\%$ , ideal for instrumentation and medical signal processing.

**HV FETs.** Drive up to four integrated FETs at 36V/1amp each for high-voltage applications.

### State-of-the-Art Power Management.

Extremely wide 0.5V to 5.5V operating range, with several low-power modes. Multiple adjustable power and clock domains for ultimate flexibility.

### CapSense

components enable you to create stylish products with capacitive touch-sensing interfaces.

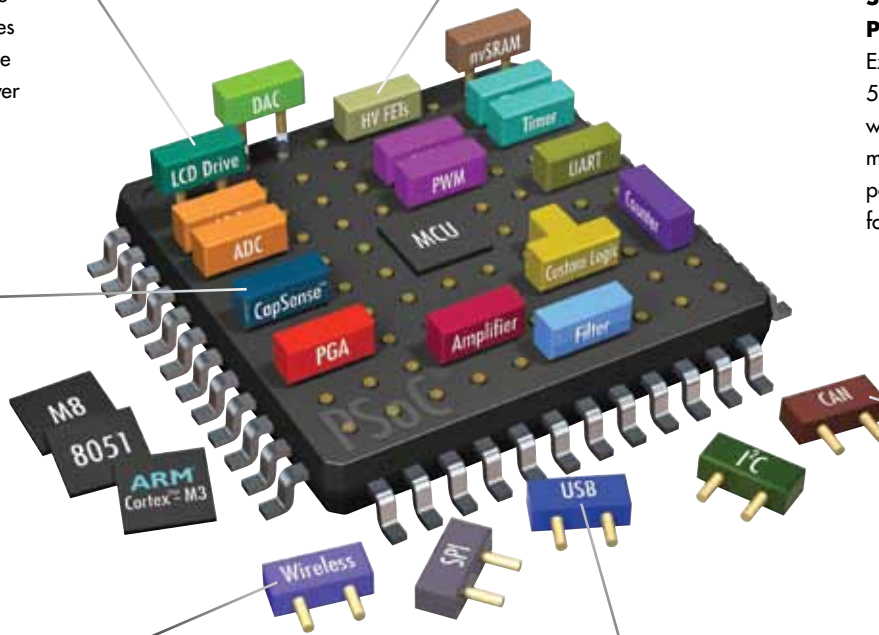

### Controller Area Network (CAN) Support.

PSoC supports this interface, which is commonly used in automotive and industrial markets.

### CyFi™ 2.4 GHz

**Low-Power RF** is a simple and power-efficient DSSS solution delivering unmatched wireless reliability with 101 dBm of on-chip link budget.

### Full-Speed USB 2.0

**support** enables embedded systems to communicate instantly with USB-enabled devices.

# THE PSoC PLATFORM

## CONFIGURABLE ANALOG AND DIGITAL BLOCKS

The union of configurable analog and digital circuitry is the basis of the PSoC platform. You configure these blocks using pre-built library functions or by creating your own. By combining several digital blocks, you can create 16-, 24-, or even 32-bit wide logic resources.

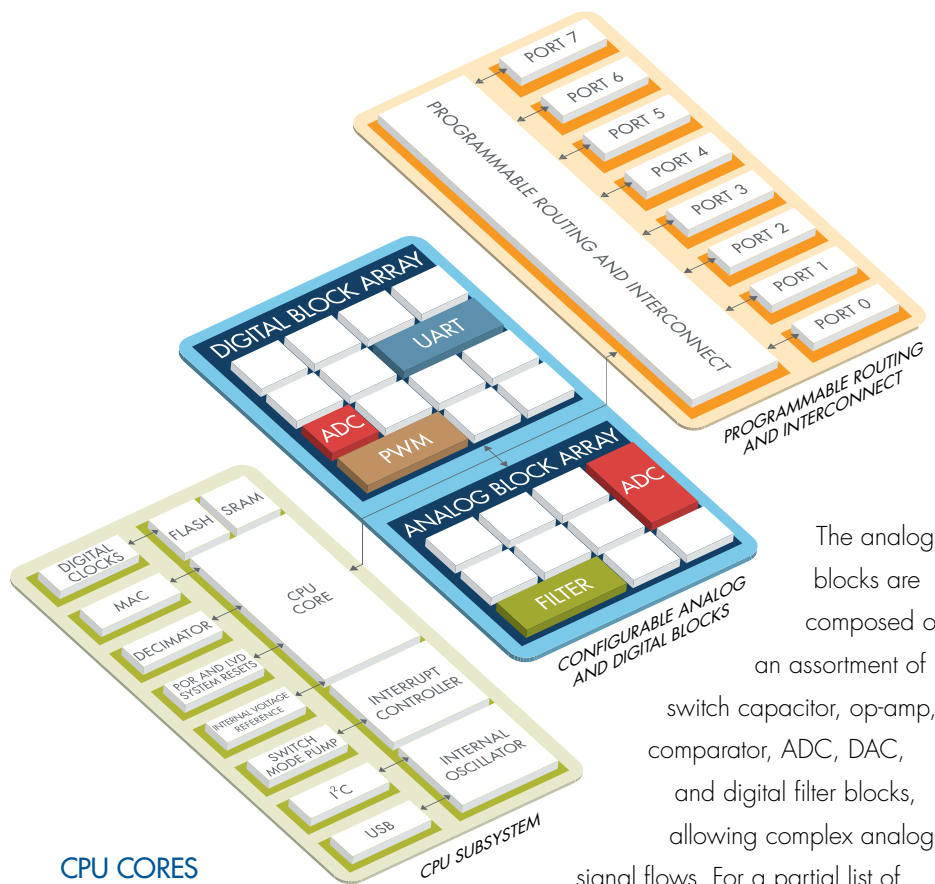

### CPU CORES

PSoC 1 – M8C  
 PSoC 3 – 8051  
 PSoC 5 – ARM Cortex-M3

The analog blocks are composed of an assortment of switch capacitor, op-amp, comparator, ADC, DAC, and digital filter blocks, allowing complex analog signal flows. For a partial list of preconfigured functions included in PSoC software, see the sidebars on the next two pages. You can modify and personalize each function to your design.

## CPU SUBSYSTEM

PSoC offers a sophisticated CPU subsystem with SRAM, EEPROM, and flash memory, multiple core options and a variety of essential system resources including:

- Internal main and low-speed oscillator
- Connectivity to external crystal oscillator for precision, programmable clocking
- Sleep and watchdog timers
- Multiple clock sources that include a PLL

PSoC devices also have dedicated communication interfaces like I²C, Full-Speed USB 2.0, CAN 2.0, and on-chip debugging capabilities using JTAG and Serial Wire Debug. The newest PSoC architectures offer industry-standard processors like the 8051 and ARM Cortex-M3 processor.

## PROGRAMMABLE ROUTING AND INTERCONNECT

This frees you to re-route signals to user-selected pins, shedding the constraints of a fixed-peripheral controller. In addition, global buses allow for signal multiplexing and logic operations, eliminating the need for a complicated digital-logic gate design.

The PSoC platform consists of configurable analog and digital blocks, a CPU subsystem and programmable routing and interconnect. PSoC lets you plug in predefined and tested IP from the PSoC library of functions, or code your own. Either way, you have the flexibility to build innovation and competitive advantage into your products.

# PSoC 1 – COST-OPTIMIZED PERFORMANCE

## PSoC 1 FUNCTIONS

PSoC 1 devices can perform hundreds of pre-configured and characterized functions. You can use them to quickly and easily build advanced mixed-signal solutions, including:

### ANALOG FUNCTIONS

#### ADCs

- Delta-Sigma 6- to 14-bit
- Incremental 6- to 14-bit

#### DACs

- 6-, 8-, and 9-bit
- 6- and 8-bit multiplying

#### Filters

- 2-pole low-pass
- 2-pole band-pass
- Modulators
- Peak detectors

### CapSense touch sensing

- V-to-I converter

### Amplifiers

- Programmable gain
- Instrumentation
- Inverting
- Comparators
- Hysteresis
- Zero-crossing

### DIGITAL FUNCTIONS

#### Timers/Counters

- 8-, 16-, and 24-bit

#### Pulse-Width modulators

- 8-, 16-, and 24-bit
- 8- and 16-bit dead band generators

#### Pseudo-Random Source (PRS)

#### Cyclic Redundancy Check (CRC)

#### Communications interfaces

- I<sup>2</sup>C master, slave, and multi-master
- SPI master and slave
- Tx, Rx, and full-duplex UART
- Full-speed USB 2.0

## PSoC 1

The PSoC 1 architecture provides integrated, flexible, programmable system-on-chip functionality for embedded control applications at a remarkably economical price. With PSoC 1, you can program a wide range of analog, digital and communication peripherals, and quickly change designs to meet ever-changing system requirements.

PSoC technology is also the foundation of Cypress's several unique and innovative solutions such as CapSense® touch-sensing, TrueTouch™ touchscreen, Intelligent lighting control, and CyFi™ Low-Power RF for embedded wireless applications.

The complete PSoC solution optimizes for the lowest possible board space and power consumption while providing the quickest time to market.

	FEATURE	PSoC 1
CONFIGURABLE ANALOG/DIGITAL	ADC	1 Delta-Sigma (6- to 14-bit)
	Sample Rate	Up to 31 KSPS (8-bit)
	Reference Voltage Accuracy	±1.53%
	DACs	Up to 2 (6- to 8-bit)
	PGA	x1 to x48
	LCD Segment Drive	Control
	Integrate Programmable Logic	No
	CapSense & Touchscreen	Up to 44 Buttons and 8 Sliders
	CPU	M8C
CPU SUBSYSTEM	CPU Performance	24 MHz, 4 MIPS
	Flash	4 KB to 32 KB
	SRAM	256B to 2 KB
	Operating Range	1.7V to 5.25V
	Power Consumption (Active@6MHz)	Active:2mA, Sleep:3uA
	Connectivity Resources	FS USB 2.0, I2C, SPI, UART
	Routing & Matrix	Manual Routing, Configurable
PROGRAMMABLE INTERCONNECT	# IO	Up to 64
	Software Development Tools	PSoC Designer and 3rd party compilers
	In-Circuit Emulation and Debug	Requires ICE Cube and FlexPods (Bond Out)
TOOLS		

# PSoC 3 & PSoC 5 – PERFORMANCE MULTIPLIED

PSoC 3 and PSoC 5 build on the original PSoC 1 architecture, adding a newly designed, high-precision programmable analog block with a breakthrough design methodology that simplifies the process of creating even the most complex systems.

## PSoC 3

Featuring a high-performance 8-bit 8051 (1CPI) pipelined RISC core offering up to 67 MHz and 33 MIPS, the PSoC 3 architecture can run more than 10x faster than a standard 8051. PSoC 3 can handle dozens of data acquisition channels and analog inputs on every GPIO pin, with a high-performance configurable digital system supporting a wide range of communication interfaces.

## PSoC 5

PSoC 5 adds the power of the ARM® Cortex™-M3 processor running up to 80 MHz at 100 DMIPS. An industry standard, Cortex-M3 processor leverages the ARM Thumb®-2 instruction set architecture and is ideal for migrating 8- and 16-bit applications to the 32-bit world. You can now run the latest audio algorithms, as well as basic video processing. Even complex motor control algorithms requiring fast signal processing such as field oriented control (FOC), high-performance waveform generation for brushless motors and high-performance sensor applications, are no problem.

## PSoC 3-PSoC 5 FUNCTIONS

PSoC 3 and PSoC 5 architectures include all of the functions of PSoC 1, plus:

### ANALOG FUNCTIONS

- Delta-Sigma 12- to 20-bit
- SAR ADC (12-bits)
- Interlocking DAC
- Trans Impedance Amplifier
- Digital Filter Block (DFB)

### DIGITAL FUNCTIONS

- Primitives like AND, OR, XOR, LUT, etc.
- Quadrature encoder for motor control
- Communications Interfaces
  - CAN
  - I<sup>2</sup>S

### ECOSYSTEM

Cypress's PSoC 3 and PSoC 5 solutions include industry-standard processors that make it easy to port your existing code to the PSoC design environment, while allowing you to tap into an established ecosystem of software tools and support.

### RTOS

- Keil® RTX51Tiny™
- Micrium® µC/OS-II™
- Segger® embOS

# ARM®

PSoC 3	PSoC 5
1 Delta-Sigma (12- to 20-bit)	1 Delta-Sigma (12- to 20-bit); 2-SAR ADC (12-bit)
192 KSPS (12-bit)	192 KSPS (12-bit) Delta-Sigma; 1 MSPS (12-bit) SAR ADC
Industrial ±0.1%	Industrial ±0.1%
Up to 4 (8-bit)	Up to 2 (8-bit) and 1 (12-bit)
x1 to x50	x1 to x50
Control + Drive (736 segments)	Control + Drive (736 segments)
Yes	Yes
Up to 62 Buttons and 12 Sliders	Up to 62 Buttons and 12 Sliders
Advanced 8051 (1CPI)	ARM Cortex-M3
67 MHz, 33 MIPS	80 MHz, 100 DMIPS
8 KB to 64 KB	32 KB to 256 KB
2 KB to 8 KB	16 KB to 64 KB
0.5V to 5.5V	0.5V to 5.5V
Active:1mA, Sleep:1uA, Hibernate:200nA	Active:2mA, Sleep:2uA, Hibernate:300nA
FS USB 2.0, I2C, SPI, UART, CAN, LIN, I2S	FS USB 2.0, I2C, SPI, UART, CAN, LIN, I2S
Automatic; Any pin anywhere	Automatic; Any pin, anywhere
Up to 72	Up to 72
PSoC Creator and 3rd party Compilers/IDEs	PSoC Creator and 3rd party Compilers/IDEs
On-chip JTAG, Debug and Trace	On-chip JTAG, Debug and Trace

# PSoC DESIGNER™ – SOFTWARE FOR PSoC 1

Experience first-of-its-kind embedded design functionality and flexibility with the PSoC Designer visual embedded design tool from Cypress.

Develop your applications using a library of pre-characterized analog and digital peripherals in a drag-and-drop design

environment. Then customize your design with C or Assembly language and the vast pre-tested libraries of code automatically generated by your selection of peripherals.

With PSoC Designer for PSoC 1 applications, you can quickly develop advanced embedded solutions, rich in analog.

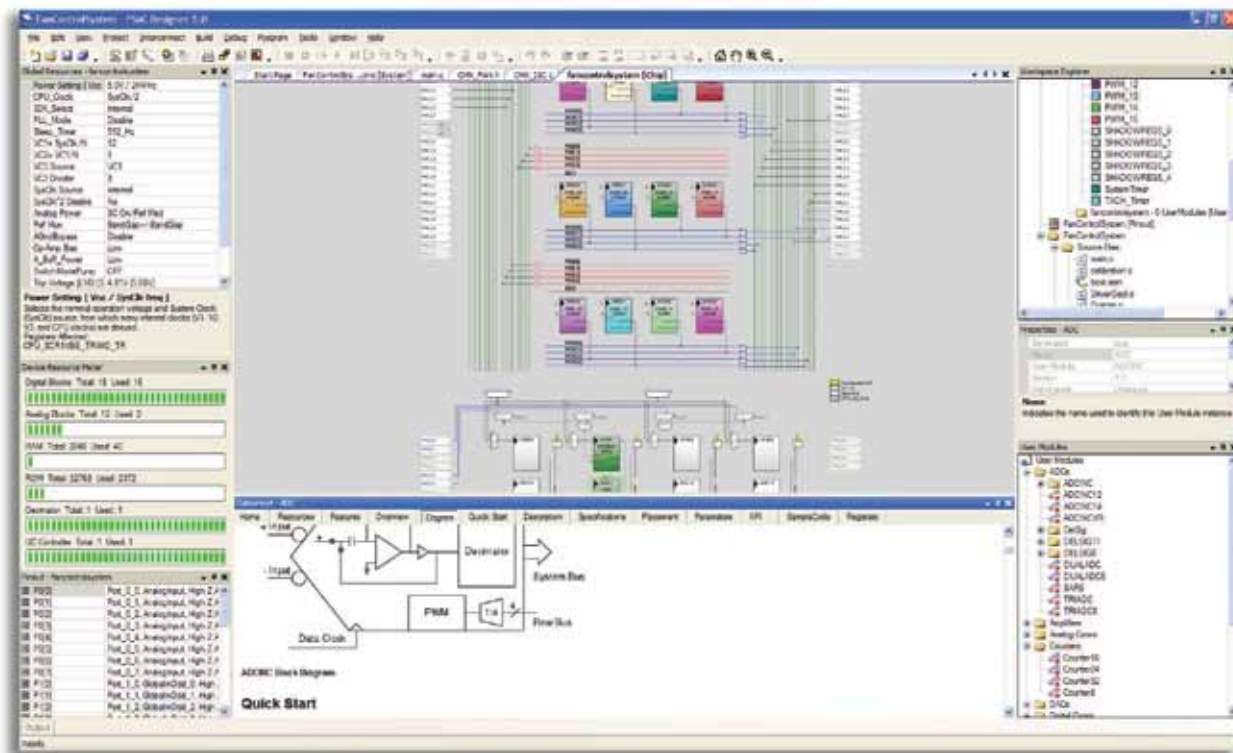

## DESIGN IN FOUR EASY STEPS

### 1. SELECT USER MODULES.

Choose from a library of preconfigured and characterized analog and digital user modules.

### 2. CONFIGURE INPUT AND OUTPUT DRIVERS.

Set up your global and user module parameters and input/output settings at any time, enabling speedy design changes.

### 3. ORGANIZE AND CONNECT USER MODULES.

Easily route global inputs and outputs to any pin via a visual programmable interconnect.

### 4. GENERATE, VERIFY AND DEBUG.

Program in C or Assembly with user module's APIs and ISRs. Test with the tool's debugger and in-circuit emulator.

# PSoC CREATOR™ – SOFTWARE FOR PSoC 3 AND PSoC 5

Cypress's PSoC Creator software is a state-of-the-art, easy-to-use IDE that introduces a game-changing, hardware and software co-design environment based on classical schematic entry—a revolutionary embedded design methodology.

With PSoC Creator, you can:

- Create and share user-defined, custom peripherals using hierarchical schematic design and Verilog entry

- Automatically place and route selected components and integrate simple glue logic normally residing in discrete muxes or 22V10s
- Trade-off hardware and software design considerations allowing you to focus on what matters: getting to market fast

PSoC Creator also allows you to tap into an entire tools ecosystem, with integrated compiler tool chains, RTOS solutions, and top production programmers to support both PSoC 3 and PSoC 5.

## FOR HARDWARE ENGINEERS

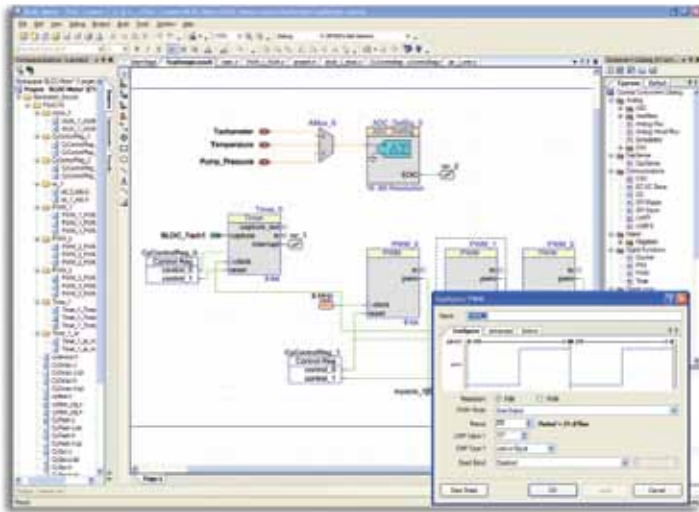

## FOR SOFTWARE ENGINEERS

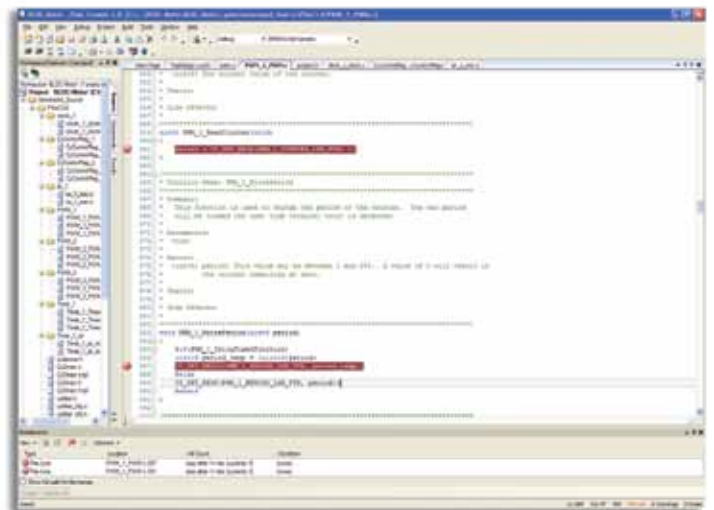

### DESIGN IN FOUR EASY STEPS

#### 1. CONFIGURE.

Choose the on-chip peripherals you need rather than settling for a device that has most of what you need but a lot of what you don't.

#### 2. DEVELOP.

Write your C-based application using standard compilers and instruction sets. Maximize your portability and reuse.

#### 3. DEBUG.

Take advantage of the powerful debug features that you've come to expect—JTAG, SWD, software breakpoints, etc.

#### 4. REUSE.

Save and reuse your hardware and software designs as components or within enterprise-wide component libraries.

# CONTACT US

## CYPRESS HEADQUARTERS

198 Champion Court  
San Jose, CA 95134 USA  
Tel: +1 (408) 943-2600  
Fax: +1 (408) 943-6848  
Toll-free: +1 (800) 858-1810 (U.S. only)  
[www.cypress.com](http://www.cypress.com)

[www.cypress.com/go/PSoC](http://www.cypress.com/go/PSoC)

[www.cypress.com/go/CapSense](http://www.cypress.com/go/CapSense)

[www.cypress.com/go/CyFi](http://www.cypress.com/go/CyFi)

[www.cypress.com/go/training](http://www.cypress.com/go/training)

## CYPRESS EDUCATION-UNIVERSITY ALLIANCE

[www.cypress.com/go/university](http://www.cypress.com/go/university)

## ONLINE TECHNICAL SUPPORT

[www.cypress.com/go/support](http://www.cypress.com/go/support)

## SOLUTIONS LIBRARY

[www.cypress.com/go/solutions](http://www.cypress.com/go/solutions)

## CyPROS CERTIFIED CONSULTANTS

[www.cypress.com/go/CyPros](http://www.cypress.com/go/CyPros)

## CYPRESS ONLINE STORE

[www.cypress.com/go/shop](http://www.cypress.com/go/shop)

## USER FORUMS

[www.cypress.com/go/forums](http://www.cypress.com/go/forums)

# JUMP START YOUR DEVELOPMENT

## STARTER KITS

Whether you are interested in capacitive sensing, light sensing, wireless, or a combination of mixed-signal applications, these FirstTouch kits are optimized for quick evaluation, featuring more sense and control options than any other starter kit in the market.

Visit [www.cypress.com/go/FirstTouch](http://www.cypress.com/go/FirstTouch) to learn more.

## SOLUTION KITS

If you are looking to quickly evaluate the performance of PSoC in a specific application, then you might consider one of our pre-built solution kits. Try our voltmeter and sensor kits to evaluate high-precision analog capabilities. Experiment with our LCD kit to see how PSoC can drive LCD displays.

For complete information on solution kits for Cypress PSoC 1, PSoC 3, and PSoC 5, visit [www.cypress.com/go/kits](http://www.cypress.com/go/kits).

## EVALUATION AND DEVELOPMENT KITS

Cypress offers a wide array of PSoC evaluation and development kits that enable you to quickly evaluate and prototype your designs. Features include CapSense capacitive touch-sensing, USB, voltage monitoring and CyFi™ Low-Power RF. All kits include a MiniProg programming unit to program PSoC devices directly on the evaluation board.

For complete information on evaluation and development kits for Cypress PSoC 1, PSoC 3, and PSoC 5, visit [www.cypress.com/go/kits](http://www.cypress.com/go/kits).

© 2009 Cypress Semiconductor Corporation. All rights reserved.  
All other trademarks are the property of their respective owners.

Job line: 0809/JFMD/EWR/JONA/XNB/AP/15K  
Part number: 2-0909PSoCBro

