

ALL RIGHTS RESERVED. NO PORTION OF THIS PUBLICATION, WHETHER IN WHOLE OR IN PART CAN BE REPRODUCED WITHOUT THE EXPRESS WRITTEN CONSENT OF SPC TECHNOLOGY.

REVISIONS		DOC. NO.	SPC-F005	Effective:	12/21/98	DCP No:	880
DCP #	REV	DESCRIPTION	DRAWN	DATE	CHECKD	DATE	APPRVD
	A	RELEASED					
1336	B	Redrawn	JWM	3/8/02	JC	3/8/02	JC

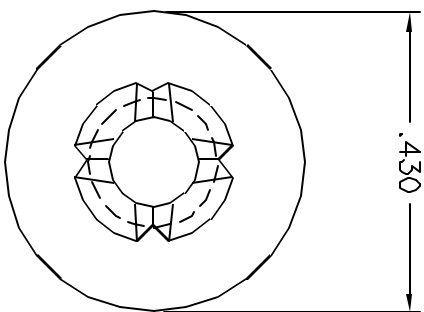
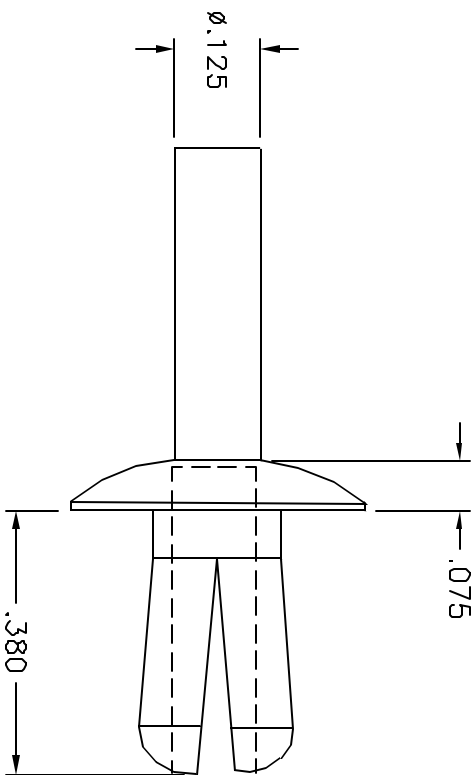

- NOTES:
- Nominal Hole size: .187 [4.75]
 - Panel Thickness: .156~.281 [3.96~7.14]
 - Head Style: Truss
 - Material: Nylon 6/6
 - Flammability: UL94V-2
 - Operating temp: -40°F to 167°F [-40°C~75°C]
 - Rivet Tool: WDRT-1

DISCLAIMER
 ALL STATEMENTS AND TECHNICAL INFORMATION CONTAINED HEREIN ARE BASED UPON INFORMATION AND/OR TESTS WE BELIEVE TO BE ACCURATE AND RELIABLE. SINCE CONDITIONS OF USE ARE BEYOND OUR CONTROL, THE USER SHALL DETERMINE THE SUITABILITY OF THE PRODUCT FOR THE INTENDED USE AND ASSUME ALL RISK AND LIABILITY WHATSOEVER IN CONNECTION THEREWITH.

Tolerances Unless
 Otherwise
 Specified: ±.005

DRAWN BY:	DATE:
JC	1/31/91
CHECKED BY:	DATE:
APPROVED BY:	DATE:



SPC TECHNOLOGY

DRAWING TITLE: Panel Mounting rivets

SIZE	DWG. NO.	ELECTRONIC FILE	REV
A	WDRT-1A	51N2380.dwg	B
SCALE:	NTS	U.O.M.: INCHES [mm]	SHEET: 1 OF 1